

NOVEMBER 2024

RALLY X
TECHNICAL REGULATIONS
CROSSCAR JUNIOR 2025



RALLY X TECHNICAL REGULATIONS CROSSCAR JUNIOR 2025

Black text = Existing text 2024

Red text = New text from 2025

Table of contents TECHNICAL RULES (CKXJ-T)

CCJ-T 0 GENERAL	3
CCJ-T 0.1 General provisions	3
CCJ-T 0.2 Fuel provisions	3
CCJ-T 0.3 Provisions about drive-by sound surveys	3
CCJ-T 0.4 Mutual safety provisions	4
CCJ-T 0.5 Competition inspection, technical and personal	4
CCJ-T 0.6 Personal safety gear for the driver	5
CCJ-T 0.7 Competition numbers	6
CCJ-T 0.8 Log Book	6
CCJ-T 0.9 Communication	6
CCJ-T 1 FRAME	7
CCJ-T 1.1 Construction	7
CCJ-T 1.2 Floor	8
CCJ-T 1.3 Hooking protection	8
CCJ-T 1.4 Roof	8
CCJ-T 1.5 Towing Connection	8
CCJ-T 1.6 Protective wall	9
CCJ-T 2 WHEEL SYSTEM	9
CCJ-T 2.1 Tire	9
CCJ-T 2.2 Wheel suspension	9
CCJ-T 2.3 Springs and shock absorbing	9
CCJ-T 3 DRIVE SYSTEM	10
CCJ-T 3.1 Engine	10
CCJ-T 3.2 Fuel system	12
CCJ-T 3.3 Exhaust system	12
CCJ-T 3.4 Start system	12
CCJ-T 3.5 Cooling System	12
CCJ-T 3.6 Electrical system	12
CCJ-T 3.7 Power transmission	12

RALLY X TECHNICAL REGULATIONS CROSSCAR JUNIOR 2025

Black text = Existing text 2024

Red text = New text from 2025

Table of contents TECHNICAL RULES (CKXJ-T)

CCJ-T 4 BRAKESYSTEM	13
CCJ-T 4.1 Service brake	13
CCJ-T 5 STERING SYSTEM	13
CCJ-T 5.1 Steering device	13
CCJ-T 6 BODY WORK	13
CCJ-T 6.1 Covering the chassis	13
CCJ-T 6.2 Mudguards.....	13
CCJ-T 6.3 Driver Seat.....	13
CCJ-T 6.4 Seat belt	14
CCJ-T 6.5 Front and side windows	14
CCJ-T 7 COMUNICATION	14
CCJ-T 7.1 Side mirrors and lighting	14
CCJ-T 8 INSTRUMENTATION	15
CCJ-T 8.1 Instrument, controls	15
CCJ-T 9 OTHER	15
CCJ-T 9.1 Minimum weight	15
CCJ-T 9.2 Maximum measurements	16

Crosscar Junior is a one seated rear wheel drive vehicle built according to the following specifics.

Vehicles with four wheel drive and all types of (turbo, compressor etc.) are all prohibited.

Automatic or half automatic gearboxes are allowed only to drivers with a disability, in all other cases the mechanical gearbox are compulsory.

CCJ-T 0 GENERAL

It's allowed to make redactions or changes to the rules during an active season if it is necessary from a safety standpoint or other important reasons.

FIA homologated cross cars can participate according to FIA cross car technical regulations.

Rally X plan/ goal:

2026: FIA Crosscar chassis only

2027: One make engine

CCJ-T 0.1 General provisions

CCJ-T 0.1.1 General

It is always the competitor responsibility to make sure that his/her vehicle fulfill all rules and regulations during the whole competition.

CCJ-T 0.1.2 Exemption from rules

The state sensor, organizers, competition leaders, judges or technical inspectors are not allowed to make exemptions from the standing rules and regulations.

CCJ-T 0.2 Fuel provisions

P1 Racings Fuels fossil free Eco 100RS is mandatory to use in Rally X 2025:

No additives of any kind are allowed.

CCJ-T 0.3 Provisions about drive-by sound surveys

An organizer may, if the competition is done during special circumstances, impose in the competition invitation that a lower noise level than 100 dB (A) will apply.

Measurements should be made in a scale that can ensure that the maximum prescribed sound limit is not broken.

CCJ-T 0.4 Mutual safety provisions

Safety gear for all competing classes.

CCJ-T 0.4.1 Seat belt**CCJ-T 0.4.1.1 Types**

The seat belt should be minimum a 5-point belt. There shall be no common connection point for the belts. The fastenings for the belts shall be in proper dimensions and connected to the vehicles chassi with minimum 8mm bolts. Alternatively welded loop. Seat belts of the type Nascar are recommended.

The seat belt shall be mounted so that all the angels are right.

Seatbelts shall be marked with ether FIA or SFI. It is allowed to wrap the belt around the pipes behind the seat.

CCJ-T 0.4.1.2 Usage

The seat belt shall be used in compliance with the manufacturer's instructions and manuals. Belts should be exchanged after a bigger collision. The belt shall be exchanged when metal parts are deformed, damaged by corrosion, if the fabric is damaged, stretched or weakness by chemicals or sunlight.

CCJ-T 0.4.1.3 Marking of damaged seat belts, National provisions

Markings shall be made on both sides of the belt on all belts in connection to the locking mechanism, with white color.

Marked equipment shall not be used in any motor sport context.

CCJ-T 0.5 Competition inspection, technical and personal

Before the competition shall all competing vehicles undergo an inspection. The inspection shall make sure that the specific demands from the technical rule book is followed and that all components to the vehicle does not have any damage that compromise the safety. Specific attention shall be made on any cracking in the frame or cage.

If the vehicle does not fulfill the technical demands or have damaged components that compromise safety, that vehicle is not allowed to participate in the competition. The Drivers overalls shall be carried by the driver during the inspection and be found clean and free from oil stains. The overalls condition is decided by the chef technician. The driver is obligated to bring and show the vehicles logbook during the inspection. The log book number shall be marked chassis production number must be stamped on a plate welded to the frame and be easily readable. The logbooks/chassi number shall be documented in the inspection papers.

Drivers that can't show their vehicles logbook can be denied participation in the competition.

CCJ-T 0.6 Personal safety gear for the driver

During scrutineering driver must wear overall. Below is a tablet about the minimum compulsory personal safety equipment during training and competition. Faulty equipment that is found during the competition inspection can be confiscated by the chef technician to be returned then the competition is finished.

Flame retardant overall
Shoes and gloves
Balaclava
HNRS/FHR protection (HANS).
Helmet and protective goggles

Flame retardant overall

FIA 8856-2000 or 8856-2018 standards.

The marking that states that the overall is FIA approved shall be embroidered on the backside of the collar and shall include the name of the maker.

CIK classed overalls are prohibited in all competing classes.

During rain or mud race CIK or any other protection overall except official FIA homologated overall is prohibited to use.

Flame retardant underwear

FIA 8856-2000 or 8856-2018 standards.

Flame retardant socks

FIA 8856-2000 or 8856-2018 standards.

Shoes

Shall be made from flame retardant material and be protecting the whole foot including the ankle.

Gloves

FIA 8856-2000 or 8856-2018 standards.

Balaclava

FIA 8856-2000 or 8856-2018 standards.

Support collar

Mandatory. Shall always be used both during training and during competition. So called HNRS/FHR (HANS) -protection is mandatory. Approved by FIA

Helmet

Approved by FIA

The following helmet provisions applies for all drivers.

All weights below shall be seen as the total weight of the helmet; this includes all extra equipment that are in the original design.

When the fitting of HNRS/FHR-protection the following applies: no drilling in the helmet is allowed, so the helmet shall have the fittings in the original design. This shall be validated with a certificate from the manufacturer.

Helmets should apply to following FIA standards: www.fia.com/sport/homologation

Common provisions marking of damaged helmets.

Marking shall be made on damaged or worn helmets that no longer follow the requirements. Markings shall be made on both sides of the chinstrap. White paint shall be used.

OBS! Marked gear shall not be used in context to any form of competition.

CCJ-T 0.7 Competition numbers

The starting number should be on the roof shark wing.

The size of the numbers should fit on the wing. Any colour combination can be used but the numbers need to be easily spotted from a distance.

Start numbers will be provided from Rally X at the first event of the season but your own numbers can be allowed by the chief technical delegate.



CCJ-T 0.8 LogBook

A logbook shall be available for all competing vehicles.

CCJ-T 0.9 Car Communication

Any form of wireless data transmission between the vehicle and any person and/or equipment is prohibited while the car is on the track. This definition does not include :

- Voice radio communications between the driver and his/her team
- Transponder from the official timekeeping

CCJ-T 1 FRAME

CCJ-T 1.1 Construction

Steel used for the frame shall have a minimum dimension of:

Round, 30mm outer diameter and material thickness of 2mm.

Square or rectangular, shortest sides shall be a minimum of 30mm and material thickness of 2mm.

Diagonal or straight pipes supports with the diameter 20 x 2 are the regulation minimum for the front part of the frame. A crash cage is mandatory. The body shall be made with cold drawn seamless pipes with the measurements 40mm in diameter and material thickness of 2mm. The cage shall not have a breaking point under 350Nm/mm² and shall be integrated into the chassis with the minimum of 6 connection points and on diagonal point. This shall be done according to the drawings AC001, AC002, AC003 and for the diagonal AD004 a pipe (30mm in diameter and thickness of 2mm) shall be secured between the frame and the rear bottom part of the diagonal pipe, this pipe can be either permanent or removable. Other alternatives for the diagonal pipe can be found on the drawings AP001, AP002, AP003 and AP004.

In drawing AP004 there is a pipe that are marked red (40mm in diameter and 2mm thickness), this pipe can be considered as integrated in the chassis and in that case the blue pipe below cannot be mounted.

All points of connection between the frame and the chassis shall be strengthened. It is prohibited to drill in the crash bar/cage.
 All additional diagonal support or enhancements shall have the minimum measurements of 20mm in diameter and 2mm material thickness.

A tube for belt attachment is free to put behind the seat

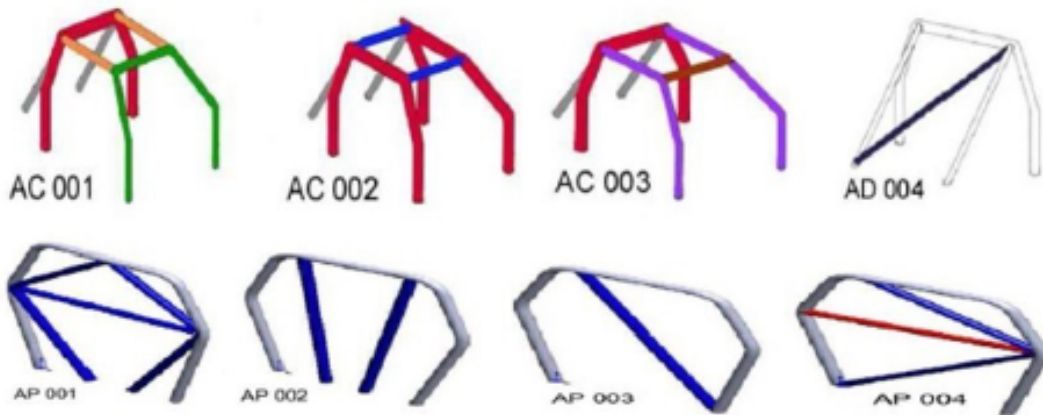

CCJ-T 1.2 Floor

The underside of the chassis shall be completely sealed from the front to the main frame, the material shall be either steel with a thickness of minimum 1mm or aluminum with a thickness of minimum 2mm.

CCJ-T 1.3 Hooking protection

A side protection shall be mounted between the wheels long side. The protection shall be made with a construction of steel pipes (30mm diameter and 2mm thick, holding frame must be minimum 20x2mm or 25x1,5mm) and be secured on both sides, covering a minimum of 60% of the length of the wheelbase. The space between this construction and the body structure shall be completely or partly filled to prevent a wheel from penetrating. Both ends of the outer pipes shall be plugged in the same material and be put in height with the center of the wheel hub +/-50mm.



CCJ-T 1.4 Roof

Minimum distance between the helmet and the roof shall be 5cm, this shall be measured with the driver in the seat.

The head frame shall be equipped with shock absorbing material closest to the head/helmet.

CCJ-T 1.5 Towing Connection

Towing must be fitted front and rear.

CCJ-T 1.6 Protective wall

A simple protection wall to safe guard against cooling liquid and motor explosion.

CCJ-T 2 WHEEL SYSTEM

CCJ-T 2.1 Tire

Winter Competition

Free choice of tire and rim, according to Rally X supplementary regulations.

On all other forms of competition this applies:

Only tires from the single supplier with the original thread pattern may be used. No additional cutting is allowed. The type of tyre (dry and wet-weather) will be defined in the tyre commercial sheet. Only these registered tyres may be used for the official practice, warm up, heats, Semi finals & Final.

All tyres from the single supplier will be marked with a specific barcode and its the teams responsibility to make sure the barcode is always readable for the technical delegate.

Tyre allowance:

four (4) rear and four (4) front tires will be the allowance per Round.

At the 1st round of the season each driver are allowed to register four (4) new rear and four (4) new front Tyres.

From the 2nd round onwards each driver may register up to two (2) new rear and two (2) new front tyres. The other tyres, to reach the max allowance may be any used tyres from earlier races during the current season.

If a change of driver mid season in a chassi the new driver will have to use the used tyres from that specific chassi from any previos round of the current season.

CCJ-T 2.2 Wheel suspension

The Wheel suspension is free, no fixed axles in the front or the back. The rear axle shall be divided.

CCJ-T 2.3 Springs and shock absorbing

Shock absorbers are free but all types of active shock absorbers are prohibited. There is a 1 per unit/wheel rule that applies for shock absorbers and they shall all be of the coil over type with screw springs. It is allowed to put more than one spring on each unit. Maximum 3 way shock absorbers are allowed but seperate expansion containers are not allowed.

With only adjusting the compression high and low speed and rebound. No other features, electronic or sensors, electrical or hydraulic "cornerback Control system that is built (stabilizer) systems may be used. Shock absorber should work as a private individual device.

Springs shall be made from steel. Springs from composite or titanium are prohibited. Springs and shock absorbers shall be made so that the bottom plate cannot touch the ground.

CCJ-T 3 DRIVE SYSTEM

CCJ-T 3.1 Engine

Approved engines:

4-stroke, 4-cylinders 600cc engine from the motorcycle production, with exemption from motorcycle engines that have not been on the market for a year or less. All repairs shall be made with parts from the original or copies with the same specification model of the engine according to the manufacturer's workshop manual. A manual shall be available at the competition inspection.

Changes to rotating parts of the engine are prohibited. In rotating parts the following are included: Cylinder including in- and outbound canals that are not removable from the cylinder head, engine block, crankcase, crank rods, pistons, flywheel, camshafts. Any form of launch control, traction control, or similar systems is prohibited.

Intake system should be original the same make as the engine. Only airbox, air intake velocity funnels and filter is free.

The exhaust manifold can be modified or exchanged.

Ignition and injection system must be original. Only original ECU, injectors and coils the same make as the engine are allowed.

Gearbox and gear ratios must be original. Sprockets and chain are free.

Following changes are also allowed:

Improvement of the cooling system including water pump, thermostat, cooler, hoses and pipes. Improvement of the lubrication system, adjustments, oil cooler and more.

Gear cut / quick shift.

Engine's Max RPM is limited by programming original ECU maximum of 9300 RPM. 9300 RPM must not be exceeded in competition or practice.

Crosskart must have Aim Mychron data logger where RPM can be checked and monitored after race. Technical scrutineering can use own data logger if needed to check RPM limit. When RPM measurement is done using external device, rpm can be exceeded max 70 RPM.

Use of Power Commander or similar is allowed only for fuel injection system. Use of Power Commander or similar for ignition system is prohibited.

600 cc Engine Control Unit (ECU) is programmed as follows:

A Map limited into max 9300 RPM is programmed to neutral gear/clutch handle map. Same map is in use at all gears. Original ignition and fuel map must be used.

Description of engine control unit (ECU) programming (Woolich Racing Tuned software) and programming the content is available on the ASN website. ASN admits application for a license to perform programming companies. Only companies approved by the ASN are eligible program and lock the program. The company must report all the programming he has done for ASN. ASN has the right to check the programming. To this end, the company the password used to lock it must be provided upon request for the use of the ASN technical delegate. ASN has the right use experts to carry out the inspection.

Engine shall be placed behind the seat.

Engine shall have an engine exhaust container or original comparison and it shall be mounted in connection by the engine. Seal holes must be prepared in bolts in engine block and cylinder head cam cover.

- All cars must bring a form from company who have programmed ECU with information of company name and contact information, description of all programming has been done in ECU and which ECU number it is. 600 cc Engine Control Unit (ECU) is programmed as follows: A Map limited into max 9300 RPM is programmed to neutral gear/clutch handle map. Same map is in use at all gears. Original ignition and fuel map must be used. Use of Power Commander or similar is allowed only for fuel injection system. Use of Power Commander or similar for ignition system is prohibited.
- Codes for the ECU must be sent via email to Technical@rallyx.se before the first race day of the season that the crosscar races at.
- Only 1 ECU is allowed in car.
- Rally X reserves the right to seal the engine at the first round or any round of the year and reserves the right for a follow up check in connection with any race weekend and/or after the final event of the year. If anything is found to not follow the regulation the driver will loose all its championship points gathered until that point of the season using the sealed engine. In case of engine failure or needs of repairs the technical delegate needs to be consolidated before any actions.

CCJ-T 3.2 Fuel system

The fuel tanks construction is free but the maximum capacity shall not be over 12 liters, One recommendation is to install a security tank, a separate deaeration system with check valve function that comes out at floor level.

The tank shall be safely mounted and connected outside of the cockpit. If the tank is mounted behind the head frame a deformation of the frame for about 4cm shall be approved without compromising the tank, if this is not possible the tank shall be protected by an additional multi-pipe construction of a diameter of 30mm. If the distance is less than 20cm to the exhaust or engine the tank shall be protected with heat isolating screen. If the tank is by the driver's side in so called pontoons a watertight metal screen shall be mounted against the cockpit.

Fuel hoses shall be properly clamped.

CCJ-T 3.3 Exhaust system

The exhaust system shall be equipped with a silencer.

CCJ-T 3.4 Start system

It shall be possible to start the vehicle from inside the cockpit.

CCJ-T 3.5 Cooling System

Installation of radiators are prohibited inside and in front of the cockpit. It is allowed to mount radiators in pontoons in the sides if these are separated by bulkheads. No part of the system shall be visible from the cockpit (radiators, hoses, lids, expansion tanks and so on).

Air intake and scoop are allowed in the roof and sides behind the head frame and in the pontoons.

CCJ-T 3.6 Electrical system

The switch that kills the engines ignition system shall be mounted and shall not be equipped with a spring-loaded button that goes back to the original position after activation. If a battery is mounted on the vehicle a main switch shall also be mounted that kills all electrical systems, the switch shall be easily accessible for both a driver strapped in the seat as well as the emergency personnel. Emergency stop buttons shall not be placed under the openable cage, it shall be placed for easy accessibility from the outside of the vehicle and it is allowed to place double emergency stop buttons. The main switch shall be placed on the left side of the vehicle. It shall be marked with a red lightning bolt on a triangular white background with a blue frame around. The sides of the triangle shall be a minimum of 100mm and one of the edges shall point towards the main switch.

The triangle shall be visible and be on the body.

A Battery shall be properly secured, Acid batteries is not allowed.

CCJ-T 3.7 Power transmission

Transmission is free, but the driveshaft shall have a common connection, the differential shall be fixed, type fixed coil, a reverse gear is allowed. Propulsion shall be achieved with a chain.

CCJ-T 4 BRAKESYSTEM**CCJ-T 4.1 Service brake**

A service brake shall be found on all 4 wheels; on the rear wheels a central brake system is allowed. A brake system shall be of the type 2 circuit and be controlled by a pedal. If leakage occurs somewhere in the system brakes shall always be maintained on 2 out of 4 wheels. A handbrake is mandatory.

CCJ-T 5 STERING SYSTEM**CCJ-T 5.1 Steering device**

Steering shall be achieved by a steering wheel.

Power steering is prohibited, steering with the help of chains, cables or hydraulic is prohibited.

Only steering on the front wheels are allowed.

The steering wheel shall be equipped with quick release.

CCJ-T 6 BODY WORK**CCJ-T 6.1 Covering the chassis**

The body must exist and cannot have any sharp or pointy extensions. The body's front shall be covering up to the center of the steering wheel. Sides shall be a minimum of 30cm from the bottom of the frame and the thickness of the material shall be at least 0,5mm. All aerodynamic constructions are prohibited in the front of the vehicle. Redirection/spray protection in the front is prohibited if they are not integrated into the body mold. A wing or spoiler in the rear is allowed if it is flat and has a maximum width, of the vehicle width and is between the head band and the rear limit of the vehicle.

No front aerodynamic devices are allowed.

No under floor aerodynamic devices are allowed.

No side aerodynamic devices are allowed.

Only one blade are allowed on the rear wing.

CCJ-T 6.2 Mudguards

Mudguards shall be placed on all wheels, they must cover a minimum of 1/3 of the wheel's circumference and the tires width. Thickness min 2mm.

The mudguards can be a maximum of 5 cm above the ground with driver inside and no sharp edges on the mudflaps are allowed.

CCJ-T 6.3 Driver Seat

The chair shall be FIA/SFI approved and can be extended use +5 years from end of homologation date if seat does not have any visible damage.

The chair shall be Secured at 4 points with the minimum of 8mm bolts.

Minimum thickness of the steel that are used for securing the seat shall be 3mm, lightweight material is prohibited.

Securing shall be welded or screwed in the frame above the floor, no securing shall be made in the floor metal. The head support shall be integrated in to the chair. The seat may not be adjusted while driving

CCJ-T 6.4 Seat belt **See CKXJ - T 0.4.1**

CCJ-T 6.5 Front and side windows

The front window shall be covered by a steel net or polycarbonate thickness minimum 3 or 5mm. The holes in the net shall be a minimum of 10x10mm and maximum of 25x25mm, the thread shall be a minimum of 2mm thick tolerance is +/- 10%.

Full front polycarbonate window may not be mounted unless windscreen wipers & windshield washer is used.

It is mandatory to use a steel net behind the front window if you use 3mm polycarbonate.

It is allowed to have polycarbonate or net, or both on the side doors. The polycarbonate must be transparent so that the driver is visible. If side doors are covered with transparent polycarbonate then it must be installed on top of safety net.

It is allowed to have an advertising space on the side window. The visible area must be at least a 2/3 third of the side door.

Front window / mesh may be covered in transparent plastic.

Nets or polycarbonate shall be mounted on the openings on both sides and cover the whole of the opening. These shall be mounted on the cages top pipes and be equipped with quick releases from both the inside and outside on the lower parts of the door.

The holes in the net shall not be above 40x40mm and it shall have a minimum thread thickness of 3mm.

If is also possible to use the following installation:

A frame provided with a metal net of maximum measurement of 60x60mm and a thickness of 2mm.

The top of the frame is equipped with hinges that are welded to the frame.

The bottom of the frame is equipped with a quick connection device that shall be easily accessible from both the inside and the outside of the vehicle.

CCJ-T 7 COMMUNICATION**Radio:**

Two way communication is allowed. The device used in the car for communication must be installed before scrutineering and approved by the technical delegate. It's the teams responsibility to ensure that they follow the laws that applies for radio communication in the country in which they are located in

CCJ-T 7.1 Side mirrors and lighting

2 mirrors are mandatory (left and right),

Each vehicle shall have the following lights mounted in the rear:

One central red light (anti-crash) of the type LED, height or diameter shall be a minimum of 50mm or light according to FIA technical list no 76. These shall be mounted between 800mm and 1400mm from the ground and shall always be on. **It must be kept switched on even with the master switch in the "off" position.** Red stop lights shall be placed symmetrical on each side of the vehicles centerline and be of the type LED. Height or diameter of the red stop light shall be a minimum of 50mm and be placed between 800mm and 1400mm from the ground. Brake lights shall solely be connected to the brake light connection on the hydraulic system. These 3 light shall be placed so that 2 of them always are visible from the rear of the vehicle in an angle of 30° on either side of the center axle, this is valid on all vehicles regardless of body shape or other aerodynamic arrangement. **Brake light should also be active when using hand brake.**

CCJ-T 8 INSTRUMENTATION

CCJ-T 8.1 Instrument, controls

Tachometer, temperature control and so on are allowed but shall be mounted so that there are no sharp edges that can cause an injury.

Camera Connection:

Camera connections are included in the inspection.

It is up to the chef technician to decide if the camera is properly secured to the vehicle.

CCJ-T 9 OTHER

CCJ-T 9.1 Minimum weight

Weight with driver min 410 kg

Ballast: Weights on these shall be maximum 10 kg a piece. Total weight of ballasts is free to acquire the correct weight stated

No part of the ballast mounting may modify the chassis construction.

This includes welding, drilling thru chassis pipes etc.

The ballast may not be mounted in the bottom guard by aluminium.

Approved ways for mounting:

- Mounting in approved brackets designed and homologated by chassis manufacturer.
- Mounting by "hydraulic" clamps around chassis pipes. The ballast needs a minimum of 4 anchor points to 4 different clamps. Note the clamp needs a steel plate for backside support and strength.
- Mounting by integration between chassis pipes (see picture below)

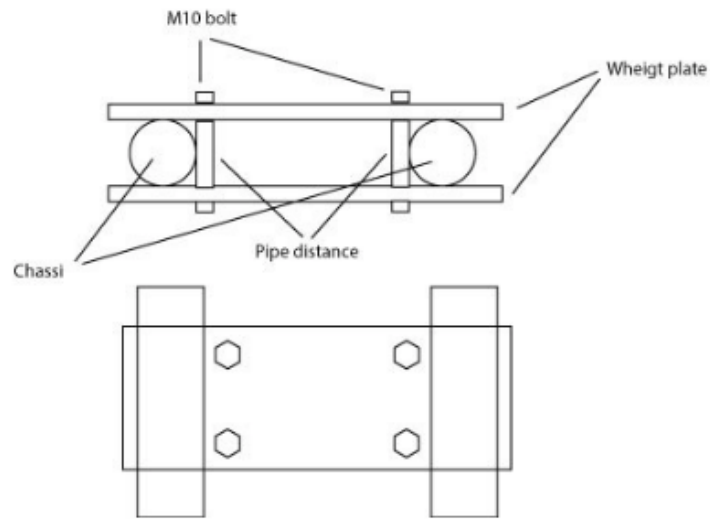

CCJ-T 9.2 Maximum measurements

Total length: 2600mm without the silencer

Total width: 1600mm

It is allowed to have the air intake on top of the vehicle but it cannot be bigger than 15cm x the width of the roof.

The gauge and axle spacers are free inside of the above mentioned limitations.