

- ART. 1** La Fórmula Winter Series adopta como Reglamento Técnico la totalidad de las normas contenidas en el Artículo 274 de la FIA - 2024 Formula 4 2nd Gen Technical Regulations
 Reglamento Técnico del Campeonato de España de F4, salvo las referidas a los discos y las pastillas de freno.
- Formula Winter Series adopts as Technical Regulations the whole rules contained in FIA Article 274 - 2024 Formula 4 2nd Gen Technical Regulations the Technical Regulations of the F4 Spanish Championship, except the ones referring to brake discs and pads.
- ART. 2** Los únicos discos de freno permitidos en la Fórmula Winter Series son los TM con referencias FRNDSC7685 (derecho) y FRNDSC7686 (izquierdo).
- The only brake discs allowed in the Formula Winter Series are the TM with references FRNDSC7685 (right) and FRNDSC7686 (left).
- Los discos de freno se describen en el Dibujo Técnico 1.
- Brake discs are described in the Technical Drawing 1.
- El espesor mínimo de un disco de freno usado es 17 mm.
- The minimum thickness of an used brake disc is 17 mm.
- ART.3** Las únicas pastillas de freno permitidas en la Fórmula Winter Series son las TM con referencia FRNPAD4393 y compuesto TMF002E (Endurance).
- The only brake pads allowed in the Formula Winter Series are the TM with reference FRNPAD4393 and compound TM002E (Endurance).
- Las pastillas de freno se describen en el Dibujo Técnico 2.
- Brake pads are described in the Technical Drawing 2.
- ART.4** Se autoriza la utilización de los sensores de amortiguador, referidos en el artículo 5.8 del documento T-421 USER MANUAL v2.1.0. Por favor vean la captura de pantalla debajo
- The use of tamer sensors, referred to in article 5.8 of document T-421 USER MANUAL v2.1.0 is authorized. Please see the screenshot below:



5.8 OPTIONAL DAMPER SENSORS

The dampers sensor kit is available from Tatuus.

Front and rear rockers are designed for the installation of dedicated linear sensors assembly, a specific adaptor allows to install the potentiometers on the shock absorbers clamps on the chassis side.

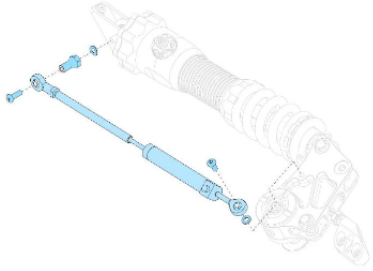
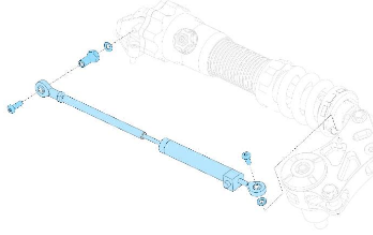
FRONT	REAR
	
Motion ratio	Motion ratio
Wheel/Pot: 2 [mm/mm]	Wheel/Pot: 2 [mm/mm]
Spring/Pot: 1,8 [mm/mm]	Spring/Pot: 1,6 [mm/mm]

For the optional sensors and adaptor looms, please refer to the T-421 spare parts catalog. For the analog spare input configuration in data logging, please refer to the engine manufacturer.

DIBUJO TÉCNICO 1 - DISCO DE FRENO / TECHNICAL DRAWING 1 - BRAKE DISK

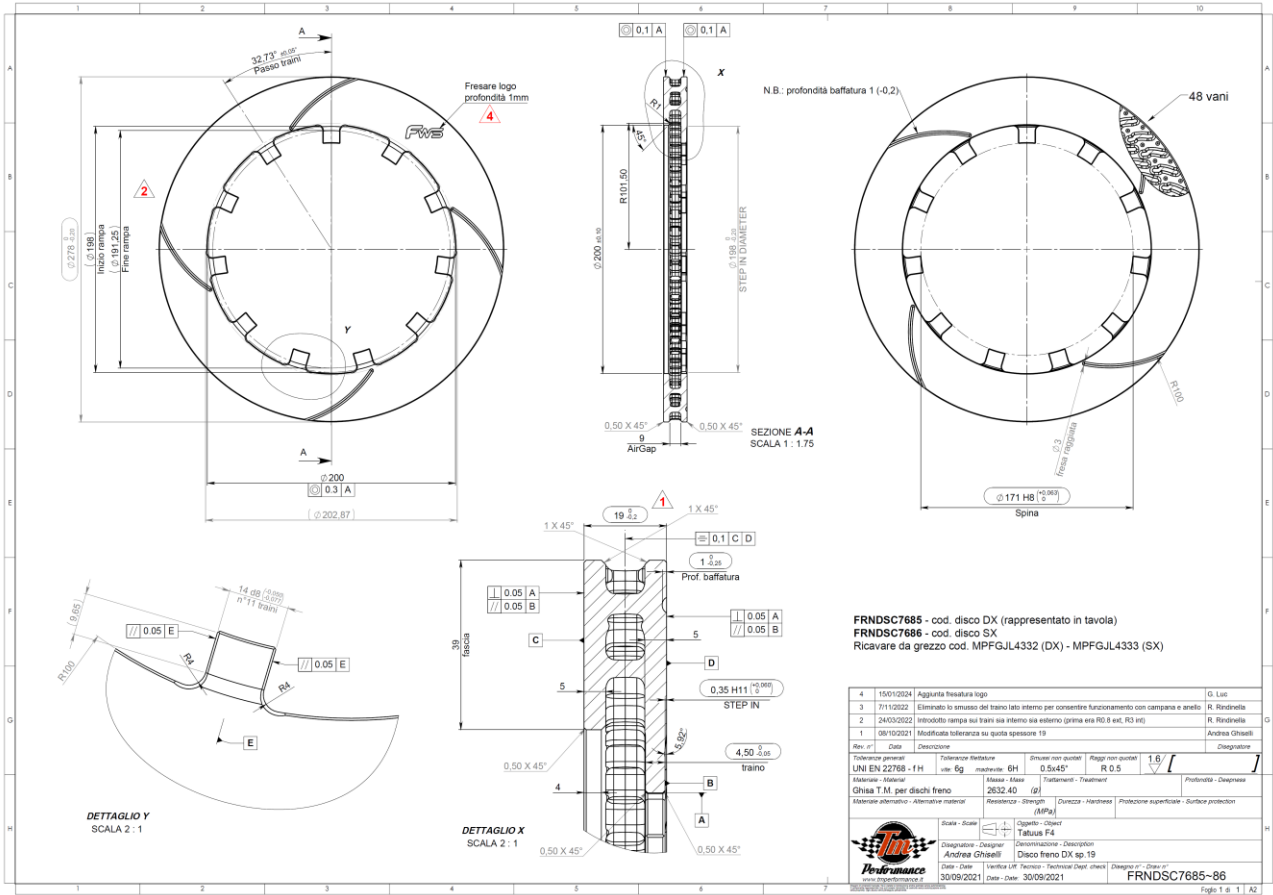

DIBUJO TÉCNICO 2 - PASTILLA DE FRENO / TECHNICAL DRAWING 2 - BRAKE PAD

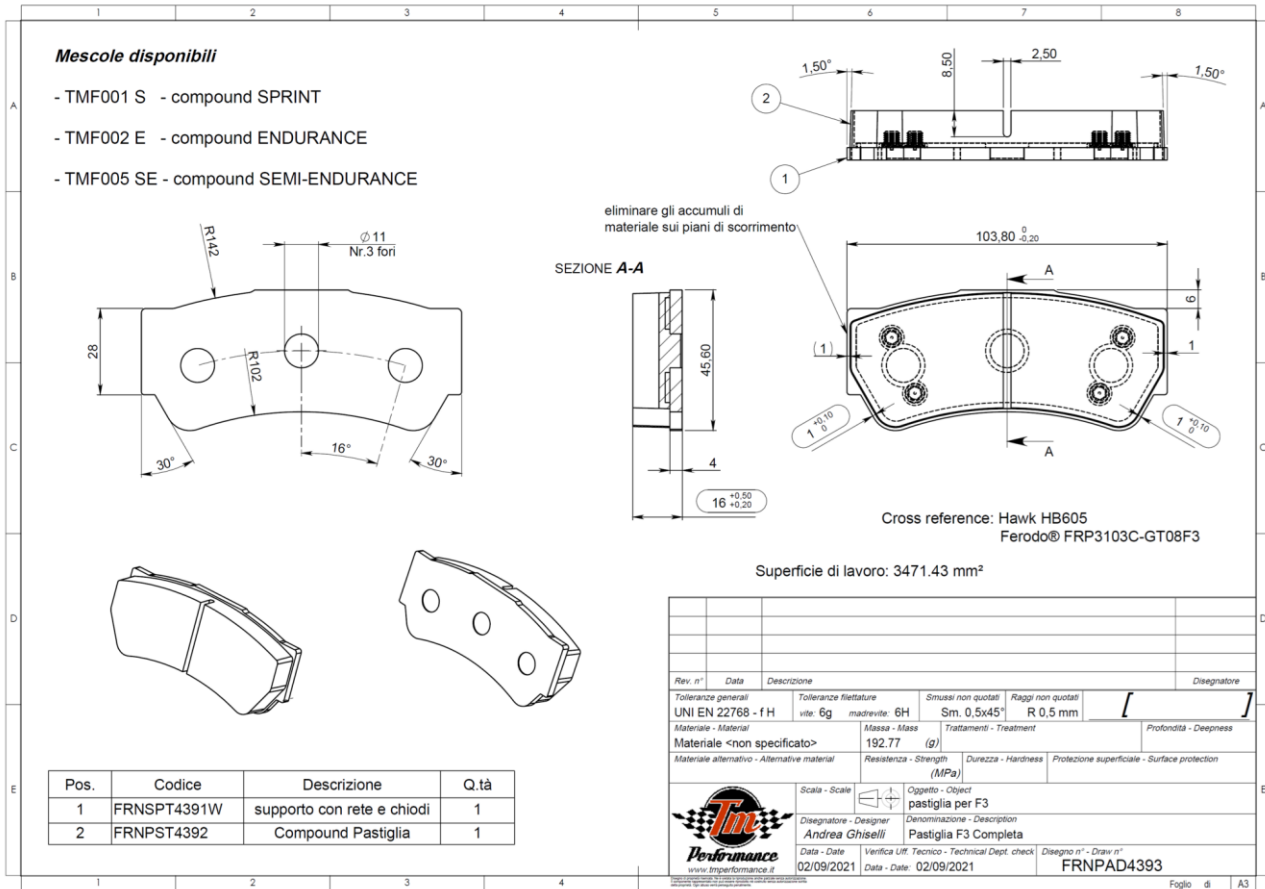

El presente REGLAMENTO queda aprobado a efectos deportivos.

Madrid, **03/01/2025**

Fdo.: Paloma Izquierdo
Directora Deportiva