

**PORSCHE**

**SPRINT CHALLENGE**  
SOUTHERN EUROPE



## Part 2 - Technical Regulations 2023

Name of the Series: Porsche Sprint Challenge Southern Europe

Status of the Events: Spanish National Status

Cup Challenge Benelux B.V., hereinafter called the Series organiser, is promoting the Porsche Sprint Challenge Southern Europe, hereafter called the PSCSE, on test and race events organized by local race organizers at the circuits of Valencia, Portimão and Barcelona.

The Porsche Sprint Challenge Southern Europe is registered as a by the RFEDA (ASN) approved national series.

Series Promoter: Cup Challenge Benelux B.V.  
Maastricht Randwyck  
Robert Schumandomein 2  
6229 ES Maastricht  
The Netherlands  
T +31 (0)43 790 1000

Contact: Lars Plato  
Series Manager  
Mobile: +31 6 15 02 71 31  
E-mail: [lars.plato@cupchallengebenelux.com](mailto:lars.plato@cupchallengebenelux.com)

## Table of Content

1.	Foreword .....	7
2.	Chapter subdivisions .....	7
3.	Source of spare parts catalogues.....	7
4.	Definitions.....	7
5.	Part numbers Porsche .....	8
<b>Part A.:</b>	<b>General Technical Regulations.....</b>	<b>8</b>
6.	General.....	8
7.	Pre-Event Scrutineering .....	9
8.	Parc Fermé .....	10
9.	Responsibility warning.....	10
10.	Accepted Cars and Divisions.....	10
11.	Exclusion of a Porsche Race Car.....	11
12.	Car Identity Passport .....	12
13.	Drivers safety equipment .....	12
13.1.	Drivers must wear the following items:.....	12
13.2.	Frontal Head Restraint System (FHR or comparable system).....	13
13.3.	Drinking system.....	13
13.4.	Cooling system.....	13
14.	Car sticker regulations .....	13
14.1.	Sticker layout and Advertising on the Drivers' equipment/on the race Car and start numbers.....	13
14.2.	Advertising.....	14
14.3.	Exclusivity rule.....	15
14.4.	Contravention of these regulations.....	15
15.	Racing suit badge regulations .....	15
16.	Noise regulations.....	15
16.1.	Exhaust system.....	15
17.	Emission regulations.....	15
18.	Radio, data, transponder, camera .....	16
18.1.	Radio system .....	16
18.2.	Data recording.....	16
18.3.	Data Offload.....	16
18.4.	Timing Transponder.....	16
18.5.	Cameras.....	16

19.	Tyres & wheels .....	17
19.1.	Tyre types.....	17
19.2.	Sessions / Tyre quota.....	17
19.3.	Registration .....	18
19.4.	Treatment.....	18
19.5.	Tyre damages .....	18
19.6.	Exceeding the tyre quota .....	18
19.7.	Driver Swap.....	18
19.8.	Guest Drivers .....	18
19.9.	Recap table .....	18
19.10.	Tyre/rim sizes .....	19
20.	Fuel .....	19
20.1.	FIA FT3 Fuel tank.....	19
21.	Fire extinguisher .....	19
22.	General safety .....	20
22.1.	Safety stands.....	20
22.2.	Fire prevention .....	20
23.	Minimum Car weight.....	20
23.1.	Weighing of Cars .....	20
23.2.	Leaving the weighing area.....	20
23.3.	Replacement and loss of Car parts .....	20
23.4.	Parc Fermé rules for Car weighing.....	20
23.5.	Weighing in below the minimum weight.....	21
23.6.	Bringing the Car to the weighing area.....	21
23.7.	Minimum Car weight per Car type .....	21
23.8.	Ballast .....	21
24.	Ground clearance of Car.....	21
24.1.	Measuring method .....	21
25.	Seals .....	22
26.	Penalty for not being compliant with the Technical Regulations .....	22
26.1.	Penalty 1.....	22
26.2.	Penalty 2.....	22
26.3.	Violation resulting in Penalty 1 & 2 .....	23
26.4.	Other violations.....	23
Part B:	Appendices .....	24

27.	Table 1 - Tyre/rim sizes .....	24
28.	Table 2 – Minimum Car weight per Car type .....	25
29.	Table 3 – Ground Clearance .....	26
30.	Table 4 - max. permissible thicknesses of the spacer washers .....	27
<b>Part C</b>	<b>: Specific Technical Descriptions .....</b>	<b>28</b>
<b>C1.0:</b>	<b>Porsche GT3 Cup, Type 992 (MY 2021-2023).....</b>	<b>28</b>
1.	General Car description .....	28
2.	Engine .....	28
2.1.	General description .....	28
2.2.	Cooling system:.....	28
3.	Power transmission (gearbox/differential lock) .....	28
3.1.	General description .....	28
3.2.	Ramp breakover angle .....	29
3.3.	Transmission emergency function .....	29
4.	Engine oil quick refill.....	29
5.	Brakes .....	29
5.1.	General description .....	29
6.	ABS System .....	30
7.	Wheel suspension .....	30
7.1.	General description front axle.....	30
7.2.	General description rear axle.....	31
7.3.	Anti-roll bars.....	31
7.4.	Shock absorbers/springs .....	31
8.	Wheels .....	32
9.	Bodywork and dimensions .....	32
9.1.	General description .....	32
9.2.	Lightweight exterior: .....	32
9.3.	Modified 911 cockpit: .....	32
9.4.	Water-based paint: .....	33
9.5.	Overall Car dimensions and overhangs:.....	33
9.6.	External bodywork (including windows).....	33
9.7.	Cockpit.....	33
9.8.	Roll cage safety padding .....	34
9.9.	Additional roof hatch accessories.....	34

10.	Aerodynamic devices.....	34
11.	Electrical equipment.....	35
11.1.	General description.....	35
11.2.	LED Lighting system:.....	36
11.3.	Optionally, the usage of the following electrical equipment is permitted:.....	36
12.	Fuel circuit.....	36
13.	Lubrication system.....	36
13.1.	Lubricants.....	36
	Attachment 1: Ballast weights.....	37
	Attachment 2: Differential lock ramp breakover angle.....	38
	Attachment 3: Differential design.....	38
	Attachment 4: Seat.....	39
	Attachment 5: Timing transponder (Mandatory for all competing Cars).....	39
	Attachment 6: Ride height measuring positions.....	40
C.2.0:	“CAYMAN CLUBSPORT” Tech. Regulations.....	41
1.	Accepted Cars.....	41
2.	Specification.....	41
3.	Principles of the Technical Regulations in accordance with.....	41
4.	Exclusion of a Porsche 718 Cayman GT4 Clubsport, type 982.....	41
5.	Replacement and loss of Car parts.....	42
6.	Ground clearance measuring point.....	42
7.	Control Devices and Software Versions.....	42
8.	Safety equipment.....	42
8.1.	Wheels combinations.....	43
C.2.1.:	Specific Tech. Regulation according to the model Porsche Cayman GT4 RS Clubsport.....	43
C.2.2.:	Specific Tech. Regulation according to the model Porsche Cayman GT4 Clubsport, ‘SRO GT4 / MR’-spec, Type 982, (‘19-‘20).....	43
C.2.3.:	Specific Tech. Regulation according to the model Porsche 718 Cayman GT4 Clubsport, ‘Trophy’-spec, Type 982, (‘19-‘20).....	44
1.	General Car description.....	44
2.	Engine.....	44
3.	Power transmission (gearbox/differential lock).....	44
4.	Brakes.....	45
5.	Steering (steering wheel/hub extension).....	45

6.	Wheel suspension .....	45
6.1.	General description front axle.....	45
6.2.	General description rear axle.....	45
6.3.	Wheelbase .....	46
6.4.	Anti-roll bars.....	46
6.5.	Shock absorbers/springs .....	46
7.	Bodywork .....	47
7.1.	General description .....	47
7.2.	External Bodywork (including Windows).....	47
7.3.	Cockpit.....	47
8.	Electrical Equipment.....	47
9.	Air Jack System.....	48
10.	Water-based paint .....	48
11.	Overall Car dimensions and overhangs.....	48
12.	Lubrication system.....	48
13.	Fuel system.....	48
13.1.	'Trophy' specifications tank plate (fuel gun) .....	48
14.	Mandatory rework .....	49
14.1.	Engine air ducts mesh:.....	49
14.2.	Safety nets: .....	49
14.3.	Safety foam Driver's door: .....	49
14.4.	Brake pressure switch: .....	49
14.5.	Roll over valve .....	49

### 1. **Foreword**

The Porsche Sprint Challenge Southern Europe (PSCSE) is a series that focusses on the gentlemen Driver and Drivers with prior track day experience. The series gives the opportunity to the Competitors to compete with Porsche 911 GT3 Cup Cars, Porsche Cayman GT4 Clubsport models, built in the years as specified. All Cars need to be in the specification such as they left the factory, except when this is clearly allowed by these Regulations. If at any time a team is in doubt about their Car's legality, either because of after-market modifications made to the Car in its history or because they have fitted original parts sold some time after the production of their specific Car, then they are encouraged to have the Car checked by the Series' Technical Manager.

### 2. **Chapter subdivisions**

The hierarchy of the chapters is shown in the example underneath.

The regulations stipulated in Part A, apply for all competing Cars or clearly indicated as an exception. Further in Part B and C are all the general rules mentioned per model group (911/Cayman). Thereafter for each model a separated chapter is dedicated to the ruled specific for the models. In some cases another subchapter is created to indicate the technical rules per model year or generation.

E.g.: Porsche 718 Cayman GT4 Clubsport, type 982 (Trophy Spec)

Must comply with the technical rules stipulated in the following chapters:

PART A => PART B => PART C => C.2.0. => C.2.3.

### 3. **Source of spare parts catalogues**

#### **Spare parts catalogues, manuals, technical info's,etc:**

##### **Porsche:**

- PMRSI (motorsport.porsche.de) => Registration form included with every new Car
- Porsche Centre
- Manthey Racing
- Further applications: [kim.huybrechts@prospeed.be](mailto:kim.huybrechts@prospeed.be),

##### **Sales Porsche Motorsport parts & Equipment:**

##### **Sales Manthey Racing Parts & Equipment:**

##### **Sales Porsche Series parts & Equipment:**

Prospeed Competition bvba  
Industrieweg 2050  
B-3520 Zonhoven  
Belgium  
[peter.reyniers@prospeed.be](mailto:peter.reyniers@prospeed.be) / [raceparts@prospeed.be](mailto:raceparts@prospeed.be)

##### **Official Michelin Tyre Supplier:**

Kronos Racing S.A.  
Rue des Pieds d'Alouettes 37  
B-5100 Naninne  
Belgium  
Charles-Antoine Hastir  
[charly@kronostyres.com](mailto:charly@kronostyres.com)  
+32 (0)479 97 15 14

### 4. **Definitions**

PSCSE Porsche Sprint Challenge Southern Europe as the organiser of the Event

TR	Technical Regulations
Team	The entrant and entrant personnel
MY	Model Year, indicates the model version
Gauge block	A calibrated tool with specific dimension, which are not variable.
PPN.	Porsche part number
MTHPN.	Manthey Racing part number
MR	Manthey Racing
✕	Mandatory rework

## 5. Part numbers Porsche

Part number are indicated by the abbreviation 'MTHPN.'. Part number starting with 'MTH' refer to 'Manthey Racing' parts. Those parts can only be found in the Manthey Racing catalogue form the concerning Car. Other part number not starting with 'MTH' are 'Porsche Motorsport' or 'Porsche Road' parts. In the Porsche Motorsport catalogue of the concerning Car is indicated if the part is a Motorsport or a road part.

## Part A.: General Technical Regulations

In 'Part A Porsche Sprint Challenge Southern Europe General Technical Regulations' are the Technical Regulations described valid for all competing Cars or mentioned otherwise in the specific regulations per Class or per Car type.

## 6. General

Everything that is not expressly permitted in these Regulations is prohibited. Permitted modifications must not result in any illegal modifications or infringements of the Regulations. Any permitted changes may only serve the intended purpose. The decision of the Series Organiser shall be final regarding any interpretation of these Regulations. The Series Organiser reserves the right to amend and extend these rules. Work may be carried out within the normal scope of Car maintenance or for the purpose of replacing parts damaged as a result of wear or accidents. Modifications and built-in components are only allowed within the scope defined further in these Technical Regulations. Parts damaged as a result of wear or accidents may only be replaced by genuine parts which are dedicated to the eligible Cars. The use of racing components manufactured by the designated manufacturer for other groups of Cars (e.g. road Cars) is prohibited. Standard fastening components on the complete Car, such as nuts, bolts, washers, spring rings, spring washers, split pins, may only be replaced by genuine parts. In the case of threads, the thread type, size and pitch are to be retained. Only genuine spare parts must be used. This means it is not allowed to use identical parts from the same manufacture without the PPN indication. If the entrant has doubts regarding any parts to be original, the entrant must check this with the Technical Manager, but it is the responsibility of the entrant to only use original parts. Parts and bodyshell must not be modified. In case of damage the Car must be repaired to its original state. The entrant who engage/signs up for the Porsche Sprint Challenge Southern Europe championship accepts and acknowledges these Technical Regulations. In any case it is the responsibility of the entrant to be in accordance with these Technical Regulations. The Porsche Sprint Challenge Southern Europe Organiser reserves the right to change the minimum Car weight and performance restrictors at all times. These organizations also have the rights to exclude or reject a Car if the Car type and/or performance doesn't fit in the global mindset or goal of the Porsche Sprint Challenge Southern Europe.

Should there be any discrepancy between the provisions of these Technical Regulations and any relevant Technical Manual, Technical Information, or Parts Catalogue, then these Technical Regulations will take precedence.



Any requirements specified in a Technical Manual, Technical Information, Software Versions and/or Parts Catalogue may be updated by Porsche AG. For Software, only the latest version is valid. Set Ups (based on the latest version) may be varied within the parameters allowed by Porsche AG. Any requirements may be varied for any specific competition by means of a Stewards of the Event' Bulletin issued at the Event.

The tools and/or measuring equipment used by the Technical Scrutineers during scrutineering is binding and any appeal or prosecution against the tools/measurement equipment in any way, is not allowed. As described further in these regulations the entrant has the possibility to use the tools/measurement equipment of the organisation, to check his Car if it is complying with these Technical Regulation. This way the entrant has the possibility to compare the measuring result, taken with the entrant's measuring equipment, with the results taken with the measuring equipment of the organisation, and adjust the Car accordingly to these Technical Regulations. The scales (used to weigh the Cars, Drivers, fuel or parts) are included in the kit with 'tools and measuring equipment' used by the scrutineer. Which means that, any appeal or prosecution against the scales used by the scrutineer, is not allowed.

At the start of the pre-Event Technical Scrutineering, which means the Technical Scrutineering before the first qualifying session, the Technical Scrutineers and/or Series Organiser indicates to the entrant where the ground clearance and Car weight will be measured. This can be done by mentioning it in the Supplementary regulation, by bulletin, any other team info or verbal message. The ground clearance is measured on a surface indicated by the Technical Scrutineers and/or Series Organiser. This 'surface' can be; a measuring plate, a surface exclusively designated for this purpose or any other surface. This surface is the reference surface and this surface is binding. Any appeal or prosecution against 'the reference surface' in any way, is not allowed.

In case of any discussion, unclarities or lack of the technical regulations, the series manager, technical manager and technical scrutineer of the Event will decide on the matter. Later on, this decision, clarification or addition to the technical regulations will be translated in a bulletin to the technical regulation.

## **7. Pre-Event Scrutineering**

Before the start of each Event a pre-Event scrutineering timetable will be made up. It is the teams (entrant) responsibility to attend the scrutineering in time, at least 5 minutes in advance. If the Competitor can't attend in time, the Technical Scrutineers must be informed before the start of the pre-Event scrutineering session. If this isn't the case a penalty will be decided by the Stewards of the Event. Per Car only 2 mechanics, 1 team manager and the Driver of the Car are allowed in the scrutineering area. All persons whose Car isn't scrutineered at the moment, aren't allowed in the scrutineering area. The Car will be checked on safety, documentation, additional ballast sealing, Car layout, general conformity, camera system...

The Competitors need to present their Cars in perfect condition. This means that the Cars need to be clean, in- and outside. Damage from previous Events will not be tolerated. Body parts must be repaired or changed, before the pre-scrutineering, if they were damaged during a previous Event. Tape as a temporary repair solution on body parts will not be tolerated by the scrutineer during the pre-scrutineering. Stickers from other series, on the outside of the Car are prohibited. All black plastic body parts and grills may not be painted. Exception; the logo of the team can be painted in white on the central radiator grill. Rear wing and its side plates may be painted. Painting and covering any lights with coloured tape or wrap is permitted. In short, the Cars must be presented at the pre-scrutineering, in the same grade of visual condition as they were delivered when they were new.

The team must take with them to the pre-Event scrutineering:

- Porsche Car (stickers + camera system + ballast,...)
- Documentation of the Car:
  - Data sheet
  - Safety cage certificate
  - Fuel tank certificate
- Additional equipment:
  - Bottle of compressed air
  - Air jack
  - Safety system to put under the Car
  - Nut gun / torque wrench
  - Wrench socket centre lock

### 8. Parc Fermé

After the qualifying sessions and the race sessions all Cars need to go immediately after the session to Parc Fermé. Parc Fermé is closed, this will be indicated with a red flag. Parc Fermé is open, this will be indicated by the red flag being removed. The flag will be shown on an easy to see spot, at the Parc Fermé location, at the PSCSE spare parts truck, at the PSCSE tent or pitlane or pit box or elsewhere. This will be communicated in the Supplementary Regulations, bulletin, or any other team info or verbally. At least one team member must be present and available to the scrutineers, at the outside borders of the Park Fermé, during the whole Park Fermé period.

### 9. Responsibility warning

In some cases, the Porsche Sprint Challenge Southern Europe organisation tolerates modifications on the accepted race Car. The modifications/exceptions are clearly written and indicated with the word 'Remark' in the Technical Regulations and only valid for a specific Class or Car type. If a subject is indicated with a 'Remark' and it is tolerated do use not original parts, it is still strongly recommended to only used original parts found in the Spare Parts Catalogue of the eligible Car.

- These modifications/exceptions could be, additional genuine spare parts available for the eligible Car, that are prohibited in a regular Porsche One Make Serie. The concerning parts, are in the Spare Parts Catalogue of the eligible Car, indicated as an option.
- These modifications could be the use of consumables. Such as; brake pads, brake disks, liquids... Only parts original to the Car type found in the Spare Parts Catalogue of the eligible Car have been tested for racing purposes. These modifications decrease the reliability of the Porsche race Car.
- Other tolerated modifications described in these Technical Regulations.

Porsche AG, Porsche Sprint Challenge Southern Europe, Cup Challenge Benelux BV, or Prospeed Competition BV (Technical Support) can't be held responsible, in any case, for the failure of the race Car and all the accompanying consequences. In all cases the entrant, including Driver and team (broadest sense of the word) are fully responsible. Even for the tolerated exceptional modifications found in these regulations, the entrant is fully responsible at all times.

### 10. Accepted Cars and Divisions

Division	Class	Car Type
Sport	PRO	Porsche 911 GT3 Cup (type 992)

	PRO-AM	Porsche 911 GT3 Cup (type 992)
Club	AM	Porsche 911 GT3 Cup (type 992)
	RS	Porsche 718 Cayman GT4 RS Clubsport
	MR	Porsche 718 Cayman GT4 Clubsport MR / SRO Spec
	PRO-AM	Porsche 718 Cayman GT4 Clubsport – Trophy Spec
	AM	Porsche 718 Cayman GT4 Clubsport – Trophy Spec

The Cars must meet these Regulations (Part A) and the technical specifications of Part B and Appendix J of the International Sporting Code in full. A change of Cars must be applied for in writing by the team (entrant) and must be approved in written form by the Series Organiser prior to the change. The decision to approve a change of Car is at the absolute discretion of the Series Organiser.

### **11. Exclusion of a Porsche Race Car**

The PSCSE has the right to exclude a Car from competing during an Event when the Car isn't repaired correctly after an incident. It doesn't matter if this incident took place during a PSCSE Event, unofficial test drive session or other championship Events. The arguments could be:

- Safety, in the broadest sense of the word.
- Car is in violation with the Technical Regulations of the PSCSE.
- Any reason that Porsche AG (in the broadest sense of the word) defines by any medium (verbally, phone call, email, letter,...).
- Damaged roll cage
- Repaired roll cage without 'Semcon' certificate.
- Damage on the front of the Car. (Reference: Technical Manual)
- Damage on the rear of the Car. (Reference: Technical Manual)

The use of aluminium components influences enormously repairs with respect to the realignment of deformed or bent components. This is due to the significantly lower yield strength and fracture elongation. As a consequence, cracks, dents or creases form faster, which in turn limits the reparability significantly. Even if there are no visible signs, damage in the material can still exist. In the Event of just a limited local repair (reforming original contour) the material loses its original strength and therefore no longer possesses the original mechanical properties.

Subject to the point of application and demands made of the material in this area, it is possible to reform aluminium sheet to a limited extent.

In this case, damaged structure is only apparent when a jig is fitted or by measuring check points on the chassis. Cast aluminium parts that show a deviation of +/- 2 mm are out of tolerance. The chassis must be replaced by a new one.

Damage Diagnosis: If casting deviations of greater than reference: 0 mm + / -2 mm are found; the chassis must be replaced

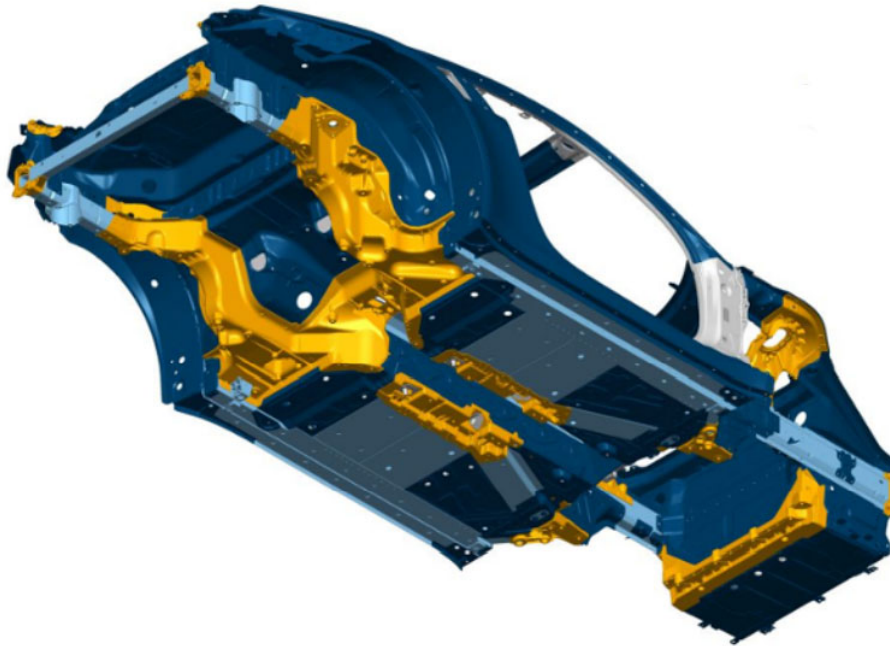

The CAD image shows the cast aluminium parts in yellow (in this case a Porsche 911 GT3 Cup (type 992)). ->Cast aluminium parts that show a deviation of +/- 2 mm are out of tolerance. The damaged chassis must be replaced by a new one.

The Series Technical Manager always will, after consulting Porsche AG, make the final decision if a damaged chassis needs replacement or can be repaired. The Series Technical Manager will supply the owner of the chassis and Porsche AG a report regardless the outcome of his decision.

These criteria apply to all Cars in all divisions.

## **12. Car Identity Passport**

- Technical passport: folder of the Car with registration documents of engine, gearbox, chassis, roll cage certificate and FT3 tank certificate (if applicable)

## **13. Drivers safety equipment**

### **13.1. Drivers must wear the following items:**

- Overalls in accordance with FIA Standard 8856-2000 ( with FIA Hologram included) or 8856-2018
- Underwear (with long sleeves and legs) in accordance with FIA Standard 8856-2000 or 8856-2018
- Balaclava in accordance with FIA Standard 8856-2000 or 8856-2018
- Socks in accordance with FIA Standard 8856-2000 or 8856-2018
- Shoes in accordance with FIA Standard 8856-2000 or 8856-2018
- Gloves in accordance with FIA Standard 8856-2000 or 8856-2018
- Helmet including FHR clips in accordance with FIA regulations (Appendix L to FIA ISC) must be worn at all times during practice, qualifying and races.

The Drivers' equipment must be checked by the scrutineer at the start of each Event. The driver must submit the "driver gear registration sheet" to the Series Organizer / Technical Scrutineer at least one week prior to the first event day. After each track session the driver can be checked for wearing the registered safety equipment by the technical scrutineer.

### **13.2. Frontal Head Restraint System (FHR or comparable system)**

The use of an FIA-approved head restraint in compliance with FIA list No. 29 is compulsory for all races and Events within the championship as well as for all races outside the championship which are organised according to these Regulations. Responsibility for the necessary modifications to the Drivers' equipment in order to enable use of such a system and installation of same in the Car in compliance with the manufacturer's instructions lies solely with the participant. The relevant manufacturer's certificate is to be presented during Technical Scrutineering.

### **13.3. Drinking system**

A drinking system with an electric pump may be used.

### **13.4. Cooling system**

A cooling system with cooling vest may be used.

## **14. Car sticker regulations**

### **14.1. Sticker layout and Advertising on the Drivers' equipment/on the race Car and start numbers**

The current FIA prescriptions for starting number and for advertising on the Drivers' equipment/on the race Car and start numbers must be respected.

The advertising decals, logos, Driver name and starting numbers as specified by the Series Organiser, must be affixed to all competing Cars during the free practice, qualifying sessions and races of the Series. The size, type, quantity and positioning are determined and announced in the "PSCSE Sticker Regulations 2023". Any breach of these Regulations may result in the participant concerned being disqualified from classification. All advertising surfaces that are not occupied as specified in the Sticker Regulations are available for the entrants' own advertising labels.

The clearance between such advertising and the mandatory labels and starting number shall be a minimum of 30 mm. retained for the entire season. The registered entrants will be informed about their starting numbers before the first race. The starting numbers markings must be fixed on all competition Cars throughout the entire Event.

The size, type, quantity and positioning of the identifications shall be determined by the Series Organiser and notification is given in the "PSCSE Sticker Regulations 2023". The team (entrant) is responsible for ensuring that the stickers on the entered Cars comply with the applicable legal regulations.

All mandatory stickers are provided by the PSCSE. Only this version of the mandatory stickers is allowed, copies of the mandatory stickers will be refused. It is forbidden to cut or to modify the dimensions of the received mandatory stickers. For example, the start number background can't be partly placed on the door, partly on the wing and cut in two. It's allowed to modify the dimensions of the window banner to avoid an overlay of the A-pillar and roof.

The mandatory window streamer is redeemable. The cost is 5000 EUR per Car per season.

All Porsche 911 Cars must be equipped with the license plate (PPN.: 9917011158A, 90014403407)

The "PSCSE Sticker Regulations 2023" will be announced before the start of the season by the PSCSE organisation.

#### **14.2. Advertising**

Upon entering the PSCSE, an entrant and her Drivers acknowledge the Sporting and Technical Regulations and thereby acknowledge that the organiser and its partners are granted the right to use all photo and video material produced during the Events of the Competitors for promotional or marketing purposes.

The use of the PSCSE name and logo is forbidden without expressly written approval by the PSCSE organisation. Even with approval from the organiser the current Porsche Corporate Identity for Porsche racing as specified by Porsche AG must always be complied with. No marketing activities connecting to the championship may be deployed without cooperation with and approval by the PSCSE organisation.

All Cars have to be presented in a presentable and representative state at the start of each Event, see technical regulations. The organiser reserves the right to make mid-season changes to the Corporate Identity and Logo layout.

Team trucks may carry the PSCSE logo only in such a way as it is specified in the Corporate Identity specified by Porsche AG for racing. A sticker layout for trucks incorporating this Corporate Identity will be made available to the teams upon request. All digital artwork required to comply with the Corporate Identity will be delivered to teams at no costs by the organiser.

Any breach of the prescriptions will be seen as a direct violation to the Regulations and penalties will be applied as such, including and up to the loss of championship points or exclusion from an Event. The Series organiser and PSCB sponsors shall acquire all rights to use sporting success for advertising purposes, without paying separate fees for this purpose.

Teams must not enter into partnerships with companies who are either in competition to Porsche AG its parent or partner companies, the official Series partners of PSCSE or who are involved in a legal dispute with Porsche AG or a company associated with the manufacturers. PSCSE is entitled to prohibit teams from entering into a partnership if the potential partner falls into one of the above categories.

The use of advertisements for companies, their products, services or brands that are Competitor products, services or brands of Porsche AG their associated companies or the Series sponsors on Cars, helmets, race suits and other Driver equipment, on team Cars or on team clothing or any other kind of advertising for these companies, products or services is strictly prohibited.

The use of advertisements for companies in the tobacco and sex industry, or political or religious advertising, or private betting and gambling operators on Cars, helmets, race suits and other Driver equipment, on team Cars or on team clothing or any kind of advertising for these companies, products or services or anything that may be deemed by Porsche AG to bring the Series into disrepute is strictly prohibited. The advertising guidelines of the FIA and ASN as well as general or legally regulated advertising bans must be observed. The team (entrant) is obliged to notify the Series Organiser of all potential partners/ sponsors. The PSCSE is entitled to prohibit teams from displaying or promoting in any manner the details of any unapproved partners/sponsors.

Team partners/sponsors must be registered with the Series Organiser no later than 7 days before the start of an Event. If team partners/sponsors are either registered late or not at all with the Series Organiser, then the entrant may be fined by the Series Organiser. The entrant and team partners/sponsors shall grant to the Series Organiser and the Series sponsors all materials depicting the championship and/or rights to use sporting success for advertising purposes, without paying separate fees for this purpose.

### **14.3. Exclusivity rule**

Team sponsors who are Competitors of the official Series partners of Porsche AG are not permitted under any circumstances. It is prohibited to communicate advertising on the Car for companies and products that are in competition to Porsche AG or its Series and cooperation partners. With regards to the exclusivity of the Series and cooperation partners of Porsche AG the following rules apply (the exclusivity rule refers either to the industry sector or to the defined product range of the company):

1. 'Michelin' is the exclusive partner for the product area "Tyres". The teams are therefore prohibited from communicating advertising for companies and products that are in competition with 'Michelin' tyres.
2. For the product area "Fuel", teams are allowed to advertise for other companies only under the following conditions and after submitting a written request to PSCSE:
  - The product brand "Fuel" must be clearly distinguishable from the group brand. Only the product brand "Fuel" is allowed to be communicated. Examples: V-Power or Ultimate
  - Max. one team with up to 6 Cars is allowed to be supported for each product brand.
3. In general, the following applies: No exemption is possible for partners of exclusivity category 1. For partners of exclusivity category 2, one release is possible on written request per product category and per team. The classification in exclusivity 1 and 2 will be defined individually per partner and is published in the separate list.

### **14.4. Contravention of these regulations**

Contravention of any of the advertising regulations may result in a fine of at least EUR 1,000, and/or refusal to participate in any Event or exclusion from the Event, in each case at the discretion of the Stewards of the Event.

### **15. Racing suit badge regulations**

The mandatory logo's and badges on the Drivers' racing overalls are described in "PSCSE Racing Suit Badge Regulation 2023". This is part of these Regulations. Any breach of these Regulations may result in the participant concerned being disqualified from classification.

### **16. Noise regulations**

Government environmental rules may override these Noise Regulations during an Event. Pre-silencers (if applicable) are mandatory at all Events.

The PSCSE organisation is not responsible for any consequences for exceeding the noise limits imposed by the circuit or local ASN. For example, due to different measuring procedures or tolerances.

#### **16.1. Exhaust system**

Only the Porsche original standard race exhaust is allowed. During all Events the 'standard' exhaust, including silencer is mandatory. The 'extra silent' pre-silencers do not need to be mounted to the car but need to be brought to the track by the team in case they are needed due to unforeseen circumstances. The parts required are listed in the currently valid parts catalogue and installation of these components is described in the handbook.

A dispensation can be granted for non-original exhaust systems. These exhaust systems can be permitted to achieve lower noise levels of a Car. The dispensation needs to be requested to the series organisation at least 3 days before the Event. The dispensation is granted by the respective technical scrutineer.

### **17. Emission regulations**

The current FIA emissions regulations are to be observed. The Cars must be equipped with a catalytic converter in accordance with the FIA exhaust gas specifications as supplied by the respective manufacturer.

### 18. Radio, data, transponder, camera

#### 18.1. Radio system

A radio system is allowed to fulfil the communication between Driver and team members. Make sure that the cable loom for the radio is properly fitted. The choice of hardware for radio reception from the "Earplug" port to the Driver is not specified but must be checked and approved by the Technical Scrutineers. When mounting fixed speakers in the Driver's helmet, the FIA helmet regulations must be strictly observed. In the case of any ambiguity, the Driver/entrant must produce proof that the components used are suitable for use in the Car (fire prevention, etc.).

#### 18.2. Data recording

A data recording system is accepted. If the Car was delivered from the factory with such a system, then the data recording system is compulsory. The use of other radio-based information transmission in the Car (e. g. telemetry) is forbidden.

#### 18.3. Data Offload

From the moment the Car enters the race track or pitlane to the end of the "Parc Fermé" during qualifying and racing, only the Series Organiser and personnel nominated by the Series Organiser are allowed to connect laptops/computers to the Cup Cars. The word 'track' is understood as the part of a circuit that is clearly demarcated to race. For the same period, no external connection (also wireless) may be made between the Car and any external equipment. It is not permitted at any time for any Competitor to read any sensors with any equipment, which are not allocated to the Competitor's own team. Any breach of this regulation will be reported to the Stewards of the Event. The PSCSE Technical Manager or his representative has at all times the right to download any of the logged data in the Car, or to request previously downloaded data by the team.

#### 18.4. Timing Transponder

Each team must equip their Car with a AMB transponder, for example from Mylaps. When a Car is shared by two Drivers, it is mandatory to have a Driver-ID installed. The timing transponder must be mounted in the front right wheel arch behind the front axle as shown underneath. Teams can buy a transponder and Driver ID from the organisation. The illustration below refers to all Cars. Consult the Series Technical Manager or Scrutineer if needed.

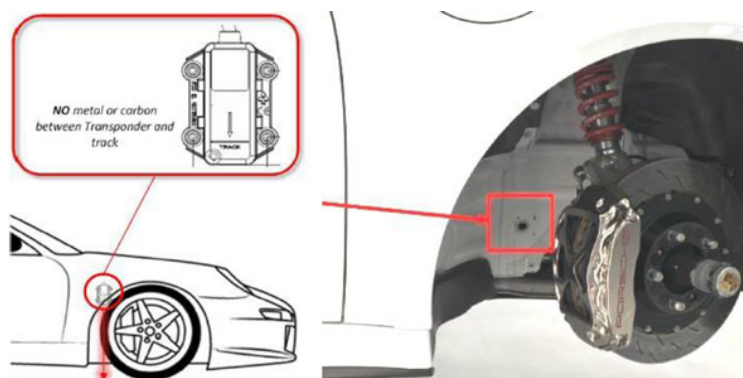

#### 18.5. Cameras

The installation of a camera system is mandatory. This must be a 'High Definition' system. This installation will be checked by a member of the Technical Scrutineers. It is the responsibility of the Competitor to provide the equipment. Each Competitor needs to make sure each session is recorded and stored on a removable memory card. We advise to foresee a spare memory card for in case one is confiscated for analysis. The PSCSE is owner of



the recorded videos and its copyrights. The videos can be used in private circumstances but can't be distributed to third parties. The camera needs to be positioned in the centre of the Car. Mounted on the x-shaped tube of the roll cage behind the seat. The camera should be mounted in a way that it records the Driver and track in front of the Car. The illustration below refers to all Cars. Consult the Series Technical Manager or Scrutineer if needed.

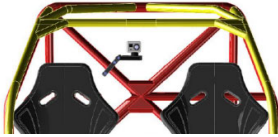

Parts should be rigid. A keycord must be attached to the camera and roll cage. This to avoid a drop of the camera into the pedal box during an incident. Make sure that the keycord doesn't block the view of the camera while braking. The use of mounting parts with suction cup are forbidden, with the exception when using a 'Racelogic VBox' System RLVBVDHD001P. The use of camera on the outside of the cockpit are prohibited.

### 19. Tyres & wheels

All tyres must be according with the PSCSE, Technical Regulations 2023 and Sporting Regulation 2023. Only Michelin tyres are allowed. During the 2023 season, for Qualifying and the races, the tyres must be ordered in advance and can only be taken at the Event from the Official Michelin Tyre Supplier - Kronos Racing S.A (§17.10). For the following sessions the following tyres are authorized:

#### 19.1. Tyre types

##### 19.1.1. Slick tyres – Free practice

Tyres bought from the Official Michelin Tyre Supplier. The season when the tyres were purchased is not specified. Those tyres can also be newly bought during the Event.

##### 19.1.2. Slick tyres – Qualifying & races

Registered tyres bought from the Official Michelin Tyre Supplier during an Event of the PSCSE 2023.

##### 19.1.3. Wet tyres

The number of wet tyres is unlimited and will not be registered.

##### 19.1.4. Joker tyres

Joker tyres will be allowed and are registered tyres bought from the Official Michelin Tyre Supplier during an Event of the PSCSE 2023.

#### 19.2. Sessions / Tyre quota

##### 19.2.1. Free Practice

Only tyres bought from the Official Michelin Tyre Supplier can be used. Those can be previously registered tyres.

##### 19.2.2. Qualifying and Races

- Maximum 8 new slick tyres can be used per Car per race Event
- Slick tyres, registered during a previous PSCSE race Event from the 2023 season
- Wet tyres
- Joker tyres, for the entire 2023 season, four additional tyres per competition number can be used as joker tyres to replace damaged tyres. These can be either front or rear axle tyres. In case a competition number misses one or more Events, the total amount of joker tyres is reduced by one tyre per missed Event. Guest Drivers may use one joker tyre per race Event. The use of one or more joker tyres is only allowed when a tyre is damaged and must be announced to the Technical Scrutineers. The

Technical Scrutineer must confirm the damage of the tyre and approve the use of a joker tyre. The marking of a joker tyre by the Technical Scrutineers final and cannot be withdrawn afterwards. If a joker tyre is marked in Qualification or Race it can be used for all races of the race Event and on future Events for free practice, qualifying or race.

### **19.3.Registration**

The registration and delivery of the tyres take place within a certain time frame, announced by the Series organizer in the Supplementary Regulations, the Event time schedule, the Drivers Briefing or an Event bulletin. The series Technical Manager reserves the right to change the registration time. The entrant has the right to request the tyre registration information stored for his/her Cars.

### **19.4.Treatment**

The pattern of the tyres may not be changed. Any chemical, mechanical or thermal treatment of the tyres is prohibited. Cleaning of the rims is permitted. The usage of a device, heat guns or any similar devices of any kind to help the removal of rubber abrasion and stones ("tyre scraping") is allowed. The use of heated covers, materials or other means that change the temperature of the tyres is prohibited for the entire duration of an Event. From the time of the pre-start until the end of the session for the Event approved tyres are not allowed to be covered. This applies for slick as well as rain tyres. Tyres can be placed outside to be warmed up by the sunshine, this can only be done in a natural way without manipulations or amplifications of the sun rays.

### **19.5.Tyre damages**

The Technical Scrutineers, in agreement with the Official Michelin Tyre Supplier, have the right to prohibit the use of a damaged tyre(s), if it seems unsafe to use.

### **19.6.Exceeding the tyre quota**

If any quota is exceeded, a penalty will be determined by the Stewards of the Event.

### **19.7.Driver Swap**

If a Driver changes a team during the season, the Driver must use his registered tyres from the previous Events during the PSCSE 2023 season.

### **19.8.Guest Drivers**

Guest Drivers must respect the same tyre regulations than full season Drivers.

### **19.9.Recap table**

Note: The overview found in the table underneath is a brief recapitulation of the detailed tyre regulations found above. In all cases the detailed tyre regulations counts and not this table.

<b>FP</b>	Open, but must be Michelin and bought from the Official Michelin Tyre Supplier
<b>Q &amp; R</b>	- Max. 8 new slick tyres per race Event (registered) - Slick tyres from previous Event (registered) - Wet tyres
<b>Slick Tyres</b>	Max 8 new tyres per race Event
<b>Joker Tyres</b>	4 additional tyres per competition number for the 2023 PSCSE. Guest Drivers may use 1 additional tyre per Event.

<b>Wet Tyres</b>	Unlimited
------------------	-----------

### **19.10. Tyre/rim sizes**

The use of any other wheels than the originally specified wheels is prohibited.

All wheels must be fitted with TPMS sensors if this is original to the Car. The rims are allowed to be painted. It is prohibited to paint or treat any functional surfaces (rim bed, contact area of wheel nuts, mounting surface of the wheel). During all sessions the wheel valve caps must be mounted.

See Table 1 in Part B – Appendices.

### **20. Fuel**

The only permitted fuel is commercial, unleaded fuel 98 RON Super Plus, or otherwise described in the Supplementary Regulations of a specific Event, in compliance with Art. 252.9 of the Appendix J (ISC) which must comply with DIN EN 228. All additives are prohibited. All chemical or thermal changes to the fuel are forbidden.

The Technical Scrutineers shall be entitled to take fuel from a participant's Car at any time during the Event. At any time of the Event until the end of the protest deadline. The Entrant must ensure that a minimum amount of 2,0kg (tolerance of 0,1kg) can be taken from the corresponding removal point (fuel removal valve) of the Car, during Parc Fermé and after Free Practice sessions. It is the team 's (entrant) responsibility to be able to take a fuel sample of min 2,0kg (tolerance of 0,1kg) at the removal point of the Car, if this is not the case the team (entrant) has the possibility to repair the fuel pump. The fuel indication on the dashboard display can't be used as an argument for not be able to tap off the minimum amount of fuel. The team need to take a marge in account, due to the fuel level gauge is not accurate when the fuel tank is almost empty.

Defuelling and refuelling of the Cars during free practice, qualifying and the race is forbidden. At any time, it is forbidden to refuel or defuel in the pit lane. Should there be any circumstances where a team is unable to use a closed-circuit fuelling system, then any fuel operations must be performed outside the team's pitbox. In a clear area of at least 3m in each direction of the Car. All personnel working in this area must wear full fireproof clothing (including shoes, gloves, goggles, balaclavas, etc.). The Car and all equipment must be grounded to earth properly and at least two 9kg ABC Dry Powder or alternatively two 5kg CO2 fire extinguishers with stand-by personnel (not involved in any fuel operations) must be present in this area. Under no circumstances must members of the public, entrants, team guests or unauthorised personnel be permitted in this area where fuel is handled as described above. It is the responsibility of the team (entrant) to ensure that such persons are excluded from the area. Smoking and hot works are prohibited when any operation involving fuel, or the fuel cell is in progress.

#### **20.1.FIA FT3 Fuel tank**

A FIA FT3 tank is mandatory for all Cars. Excluded from this rule are Porsche models that are delivered from the factory without FIA GT3 tank. The standard tank as delivered from the factory is mandatory for this Car type.

### **21. Fire extinguisher**

From the moment that the race Car leaves the team's (entrant) tent or garage to attend a Free practice, Qualifying or Race session until the end of Parc Fermé, the Car's fire extinguisher must be active.

**22. General safety****22.1. Safety stands**

The use of safety stands (securing the Car from dropping unintentionally from the air jacks) for any type of work underneath the Car is mandatory. Any infringements will be reported to the Stewards of the Event and penalized at the full discretion of the Stewards of the Event.

**22.2. Fire prevention**

It is the team (entrant) responsibility to have min two 9kg ABC Dry Powder or alternatively two 5kg CO2 fire extinguishers present in the teams' tent/awning/garage box at all time. The fire extinguishers must be clearly visible and easily accessible. Any non-compliance will be reported to the Stewards of the Event and penalized at the full discretion of the Stewards of the Event.

**23. Minimum Car weight**

It is the entrants' responsibility to ensure that at all times during the Event the mandatory minimum weights are reached. The minimum weight must also be observed when the levels of operating liquids are under minimum level. The Technical Scrutineers shall specify a weigh scale for the checking of weight of the Cars. It is referred to here as the "official scale". The installation of ballast is permitted. These must be installed at the position of the passenger's seat. At no time during an Event is the weight of a Car allowed to be less than the mandatory minimum weight. On the way from the circuit to the Parc Fermé and in the Parc Fermé itself, and on the way to the post-qualifying or race Technical Scrutineering, under no circumstances is weight allowed to be added to the Car. Prior to weighing a Car, the Technical Scrutineers will give the order to a team member to remove the remaining fuel from the fuel tank. After weighing, the value plus 2.0 kg of weighing tolerance shall be added and this result shall be referenced against the mandatory minimum weight, which must be reached. The mandatory minimum weight of a Car is specified further in these regulations. The minimum weight of a Car consists of Weight of the Car with empty fuel tank.

**23.1. Weighing of Cars**

Weighing of Cars is carried out on the official scale. If a Driver is given the signal that his/her Car has been selected for weighing, he/she must take the shortest route possible to the weighing area and turn off the engine. If a Car cannot reach the weighing area under its own power, it must be brought to the weighing area solely by marshals. If this is not possible, then the Technical Scrutineers can assign other persons for this purpose.

**23.2. Leaving the weighing area**

Without the consent of the Technical Scrutineers, the Car is not allowed to be removed.

**23.3. Replacement and loss of Car parts**

All Car parts that were replaced during the qualifying session and race must be presented to the Technical Scrutineers without request for inspection. The parts that were removed from the Car will be marked by the Technical Scrutineers if necessary and are not allowed to be modified in any way afterwards. These parts must remain in the pit or in the Technical Scrutineering tent in sight of the Technical Scrutineers or their assistants until released by the Technical Scrutineers. These parts can be considered when determining the weight instead of the replaced parts.

**23.4. Parc Fermé rules for Car weighing**

Cars that have been specified for weighing are subject to Parc Fermé Regulations. It is forbidden to add or remove any substance to/from the Car after it has been selected to be weighed. The same applies during the weighing process and after the end of the race. Excluded are actions of the Technical Scrutineers.

### **23.5. Weighing in below the minimum weight**

If, during the post qualifying or post-race weighing procedure, the Car is found to be below the currently applicable minimum weight, the Car will immediately be weighed for a second and a third time on the same scales and in the same condition. The maximum value of the 3 weights recorded is regarded as the actual weight of the Car. Falling below the minimum weight will be reported to the Stewards of the Event.

### **23.6. Bringing the Car to the weighing area**

It is the entrant's responsibility to ensure that the race Car entered by him/her can be brought directly to the weighing area when instructed by the Stewards of the Event or the Technical Scrutineers at any time during the Event. In any case, Parc Fermé rules apply to the Car from the moment of the order until the termination of the weighing process. Moreover, Parc Fermé rules apply to the route to the weighing area and in the weighing area itself. In this area, the only activities on the Car are those expressly permitted by the aforementioned persons. If a Car is not presented for weighing despite a request, the Technical Scrutineers will inform the Stewards of the Event.

### **23.7. Minimum Car weight per Car type**

See Table 2 in Part B – Appendices

### **23.8. Ballast**

The installation of the ballast box as described in the Parts Catalogue is mandatory.

The installation of ballast is permitted. Only original ballast components must be used to add weight to the Car to reach the minimum Car weight. These must be installed in the provided holders at the position of the passenger's seat in accordance with the instructions in the designated Technical Handbook. The ballast weights are identified in the designated spare parts catalogue.

## **24. Ground clearance of Car**

The minimum ground clearance of the Car with the Driver in the Car, tyres at 2.0 bar  $\pm$ 0.1 bar air pressure, must not be less than the specified dimension, as measured at the specified measuring points, at any time during the Event.

### **24.1. Measuring method**

The minimum ground clearance of the Car is checked on the measuring surface, using a height gauges, gauge block or similar. The minimum ground clearance of the Car (with the Driver in the Car), tyres at 2.0 bar  $\pm$ 0.1 bar air pressure must not be less than the specified dimension, as measured at the specified measuring points, at any time during the Event. The ground clearance of the Car is measured on a surface indicated by the Technical Scrutineers. This 'surface' can be a measuring plate, a surface exclusively designated for this purpose or any other surface. The measurement is checked with the Car in the state that it ended its last session. This means with the same tyres that the Driver ended its last driving session. The remaining fuel, left over from the last driving session, must stay in the Car for the ground clearance measurement. The ground clearance measurement is done with the Driver on board that ended the last session, together with his full Drivers equipment. If the measuring can be accessed under the measuring points described above, the requirement to comply with the minimum height is satisfied. Any measuring tolerances will be taken into account by the Technical Scrutineers. The Technical Scrutineers may at any time in their absolute discretion check the ground clearance measurement. The Technical Scrutineers may also use instruments such as measuring calliper or depth gauges to determine the Car height. Failure to reach the minimum height will be reported to the Stewards of the Event.

During the qualifying sessions, including during the break, in case of a qualifying with a break in the pit lane, it is strictly forbidden to modify the ground clearance at the front drive train of the Car, by adjusting the spring rest and/or counter nut of the shock absorbers.

See Table 3 in Part B – Appendices.

The suspension is allowed to be modified within the scope of the specified setting range. All genuine parts must be retained. The max. permissible thicknesses of the spacer washers in the front and rear axle control arms to change the camber angle per Car type are shown underneath. Furthermore, it is optional to hide the camber shims with aluminium tape.

All bearing points of the front and rear control arms must be left in the position in which they are delivered. The adjustment of the excenter screw at the front upper control arm mounting bracket, within its specified setting range, is permitted."

An alternative mounting ring may be used instead of Z Clamp Fitting (Pn: 9F1253543A). However, it must be ensured that the alternative clamp is not colliding with any of the other parts. The maximum permissible overhang of the alternative clamp is 10mm.

See Table 4 in Part B – Appendices.

The non-removable spacer (Pn: 9F1505184) of the rear lower control arm will be included when determining the combined thickness of the camber spacer washers.

If measured, the camber gauge available at the scrutineering is binding.

A change to the maximum permissible combined thickness of the spacer washers in the front and rear axle control arms can be announced by Stewards of the Event' bulletin at any time before or during any Event.

## **25. Seals**

The engine needs to be sealed by PAG and gearbox does not need to be sealed.

## **26. Penalty for not being compliant with the Technical Regulations**

### **26.1. Penalty 1**

Not being in compliance with the Technical Regulations during the qualifying sessions and/or the post Technical Scrutineering of the associated session, will be reported to the Stewards of the Event and will be penalised with the cancellation of the qualification times achieved by the Driver concerned. The Driver is allowed, however, to start in the race from the last place on the starting grid. All other Drivers, including unqualified Drivers, who would be standing on the starting grid behind the penalised Driver will move up one place on the starting grid of the associated race. If more than one Driver is penalised with the same penalty, their order on the back of the starting grid will be defined by their best qualification times.

### **26.2. Penalty 2**

Not being in compliance with the Technical Regulations, during a race session and/or the post Technical Scrutineering of the associated session, will be reported to the Stewards of the Event and will be penalised with disqualification from the points classification for that race.

**26.3. Violation resulting in Penalty 1 & 2**

Penalty 1 & 2, as described above, are valid and must be applied in case of any infringement observed regarding the topics listed underneath.

- Minimum Car weight
- Minimum ground clearance
- Maximum camber spacer
- Wheelbase dimensions
- Wing dimensions and profile
- Use of unregistered tyres during Qualifying or Race
- Tyres fitted or any illegal manipulation of them

**26.4. Other violations**

Other infringements against the Technical Regulation will result in a penalty decided by the Stewards of the Event or otherwise specifically described in these Technical Regulations. The penalty decided by the Stewards of the Event could be penalty 1 & 2.

**Part B: Appendices****27. Table 1 - Tyre/rim sizes**

	<b>Car Type</b>	<b>Slick Front</b>	<b>Slick Rear</b>	<b>Rain Front</b>	<b>Rain Rear</b>	<b>Rim Front</b>	<b>Rim Rear</b>
<b>GT3 Cup</b>	Porsche 911 GT3 Cup, type 992	30/65-18	31/71-18	30/65-18	31/71-18	12Jx18 ET23,5mm	13Jx18 ET44,5mm
<b>GT4 Clubsport</b>	Porsche 718 Cayman GT4 RS Clubsport, type 982	27/65-18	30/68-18	27/65-18	30/68-18	9Jx18 ET41mm	10,35Jx18 ET47,5mm
	Porsche 718 Cayman GT4 Clubsport, type 982 (MR / SRO GT4 Spec)	25/64-18	27/68-18	25/64-18	27/68-18	9Jx18 ET41mm	10,35Jx18 ET47,5mm
	Porsche 718 Cayman GT4 Clubsport, type 982 (Trophy-Spec)	25/64-18	27/68-18	25/64-18	27/68-18	9Jx18 ET41mm	10,35Jx18 ET47,5mm

GT3 Cup need to use the Michelin N3 (front) and the N3R (rear) type tyres.

GT4 Clubsport need to use the N2 type tyres (front and rear).

Cars of the type Porsche 718 Cayman GT4 RS Clubsport need to use the Michelin M range type tyres.



**28. Table 2 – Minimum Car weight per Car type**

	<b>Car Type</b>	<b>Weight</b>
<b>GT3 Cup</b>	Porsche 911 GT3 Cup, Type 992	1293kg
<b>GT4 Clubsport</b>	Porsche Cayman GT4 RS Clubsport, type 982	1330kg
	Porsche 718 Cayman GT4 Clubsport, type 982 (SRO GT4 / MR Spec)	1295kg
	Porsche 718 Cayman GT4 Clubsport, type 982 (Trophy Spec)	1325kg

**29. Table 3 – Ground Clearance**

	<b>Car Type</b>	<b>Front</b>	<b>Rear</b>
<b>GT3 Cup</b>	Porsche 911 GT3 Cup, Type 992	72mm	106mm
<b>GT4 Clubsport</b>	Porsche 718 Cayman GT4 RS Clubsport, type 982	79mm	100mm
	Porsche 718 Cayman GT4 Clubsport, type 982 (SRO GT4 / MR Spec)	101mm	94mm
	Porsche 718 Cayman GT4 Clubsport, type 982 (Trophy Spec)	85,0mm	95,0mm

**30. Table 4 - max. permissible thicknesses of the spacer washers**

	<b>Car Type</b>	<b>Front</b>	<b>Rear</b>
<b>GT3 Cup</b>	Porsche 911 GT3 Cup, Type 992	20,0mm	15,0mm
<b>GT4 Clubsport</b>	Porsche Cayman GT4 RS Clubsport, type 982	18,0mm	18,0mm
	Porsche 718 Cayman GT4 Clubsport, type 982 (SRO GT4 / MR Spec)	18,0mm	18,0mm
	Porsche 718 Cayman GT4 Clubsport, type 982 (Trophy Spec)	18,0mm	18,0mm

For the competition at Portimão the maximum permissible combined thickness of the spacer washers in the front and rear axle control arms off all GT3 Cup Cars are:

- Front axle: 19.0 mm
- Rear axle: 13.0 mm

And for the GT4 Clubsport Cars are:

- Front axle: 10.0 mm
- Rear axle: 10.0 mm

## Part C: Specific Technical Descriptions

All Cars must meet the technical descriptions of these Regulations and Appendix J of the International Sporting Code in full. In addition to the Technical Regulations according to Part A in these Regulations, the following specific technical descriptions are applicable for the respective Car types. Technical acceptance of the Cars is undertaken by the Technical Scrutineers.

### C1.0: Porsche GT3 Cup, Type 992 (MY 2021-2023)

#### 1. General Car description

Porsche 911 GT3 Cup (type 992), MY '[21-'23]

Concept: Single-seated, near-standard race Car based on the Porsche 911 GT3. For further general descriptions the entrant shall refer to the respective paragraph of this technical regulations.

#### 2. Engine

##### 2.1. General description

- Aluminium six-cylinder rear-mounted boxer engine
- 3,996 cm<sup>3</sup>; stroke 81.5 mm; bore 102 mm
- Max. power: 375 kW (510 hp) at 8400 rpm
- Max. rpm: 8750 rpm
- Single-mass flywheel (Pn:9F1105272)
- Water cooling with heat management for engine and gearbox
- Four valves per cylinder
- Variable cam phasing (Intake & Exhaust)
- Direct fuel injection
- Required fuel quality: minimum 98 octane, unleaded
- Dry-sump lubrication
- Electronic engine management (Bosch MS 6.6)
- Race exhaust system with regulated race catalytic converter
- Rear silencer with centred exhaust pipes
- Electronic acceleration pedal

##### 2.2. Cooling system:

The classic coolant is prohibited. The cooling system must be filled up with regular water that is mixed with at least 10% (approximately 2.5liters) of anti-corrosion agent with Porsche spare part number 99710690790.

Two coolant supply pipes are allowed to be used as described underneath. The parts listed below must only be installed in the subsequent combination. If one of the components is changed all other accompanying parts must also be changed at the same time.

#### 3. Power transmission (gearbox/differential lock)

##### 3.1. General description

- Porsche six-speed sequential dog-type gearbox
- Gear ratios:
  - Ring & pinion gear 15/23 i = 1.533

- Final drive 16/39  $i = 2.438$
- 1st gear 13/41  $i = 3.154$
- 2nd gear 17/40  $i = 2.353$
- 3rd gear 20/37  $i = 1.850$
- 4th gear 24/36  $i = 1.500$
- 5th gear 24/30  $i = 1.250$
- 6th gear 28/30  $i = 1.071$
- Internal pressure-oil lubrication with active oil cooling by oil-water heat exchanger
- Mechanical limited slip differential
- Triple-disc sintered metal race clutch (Assembly: 9F1141015,
- Paddle shift with electronic shift barrel actuator

### 3.2. Ramp breakover angle

The ramp breakover angle of the differential lock is 52° (traction) and 35° (overrun). The ramp angles are determined from the axis of rotation (Attachment 2). The number of friction plates and the assembly order shall correspond to the image shown in Attachment 3 and must not be changed. The fitted friction plates must comply in terms of part number, allocation and specification. (see parts catalogue of the eligible Car)

### 3.3. Transmission emergency function

After the transmission emergency function has been switched on by the Driver, the Car must immediately return to the pit lane. The Car is not allowed to leave the pit lane again until this function has been deactivated.

## 4. Engine oil quick refill

The use of the optional "oil quick filling kit" as shown in the catalogue is permitted, as long as the mounting is compliant with the Porsche AG's official mounting instructions. The hole in the engine lid necessary to fit the quick oil fill must be fully covered by clear Helicopter tape. The use of the engine oil quick fill in pitlane during any PCCB Event is prohibited.

## 5. Brakes

### 5.1. General description

Two independent brake circuits with brake pressure sensors for front and rear axle, adjustable by the Driver via brake balance system derivative sensors & harness for retrofitting an ABS system

#### Front axle:

Six-piston aluminium racing brake calipers in mono-bloc design with "anti-knock-back" piston springs

- Ventilated and grooved steel brake disc 380 mm diameter, 32mm thick, with aluminium disc bell
- Racing brake pads
- Optimized ventilation routing

#### Rear axle:

- Four-piston aluminium racing brake calipers in mono-bloc design with "anti-knock-back" piston springs
- Ventilated and grooved steel brake disc 380 mm diameter, 32mm thick, with aluminium disc bell
- Racing brake pads
- Optimized ventilation routing
- The spoilers on the front wishbones (Pn:9F1407811 and 9F1407812) must be mounted and is mandatory for each Event.

Only Cars with the brake calipers are permitted that correspond with the delivery conditions. It is not permitted to modify the Car to endurance brake calipers, even if they might be listed in the parts catalogue.

Only standard master brake cylinders are permitted for the 2 brake circuits on the

- Front axle: (diameter: 19.1 mm, Pn: 9F1611011B)
- Rear axle: (diameter: 15.9 mm, Pn: 9F1611011C)

### **Front axle:**

- Aluminium 6-piston fixed calipers, one piece
- Internally vented brake discs, diameter = 380 mm, 32 mm thick,
  - Front Left: Assembly: Pn: 9F1615283A
  - Front Right: Assmebly: Pn: 9F1615284A
- Racing brake pads (Pagid). Pn: 9F1615432

### **Rear axle:**

- Aluminium 4-piston fixed calipers, one piece
- Internally vented brake discs, diameter = 380 mm, 32 mm thick,
  - Rear Left: Assembly: Pn: 9F1615583A
  - Rear Right: Pn: 9F1615584A
- Racing brake pads (Pagid). Pn: 9F1615432B

A knock-back spring must be installed in each case under each brake piston of all brake calipers. External thermal or chemical treatment of these springs is prohibited.

Only the following parts are allowed to be used:

- Front axle: TBA
- Rear axle: TBA

## **6. ABS System**

The use of any system working like an ABS system or traction control is allowed.

All Porsche 911 GT3 Cup (type 992) are allowed to be equipped with the Bosch Motorsport ABS system (hydraulic power unit PPn:9F1614095).

The ABS system must not be modified in any way. All genuine parts must be retained and can only be replaced by identical parts. These parts are stated in the Porsche 911 GT3 Cup (Type 992) parts catalogue as released on the Porsche Motorsport Racecar Service Information (PMRSI).

The Competitor must ensure that the working parameters are identical to the ones reported by the supplier in the setup configuration.

Setup can only be modified within the scope of the specified setting range (Dry-Wet switch, 12 positions switch).

The Competitor must ensure that the correct ICD and IPS setups are used.

## **7. Wheel suspension**

### **7.1. General description front axle**

- Double wishbone suspension, adjustable ride-height, camber and toe
- Forged control arms and top mounts: Stiffnes optimised, heavy duty spherical bearings with dust protection.
- Wheel hubs with centre lock
- Shock absorbers with motorsport specific valve characteristic, non-adjustable

- Double-blade-type anti-roll bar
- Electric power steering with external control function for easy Car manoeuvring
- Tyre pressure monitoring system

### 7.2. General description rear axle

- Multilink rear suspension, adjustable in height, wheel camber and track
- Forged control arms and top mounts: Stiffnes optimised, heavy duty spherical bearings with dust protection.
- Wheel hubs with centre lock
- Shock absorbers with motorsport specific valve characteristic, non-adjustable
- Double-blade-type anti-roll bar
- Tyre pressure monitoring system

#### 7.2.1. Camber

The suspension is permitted to be modified within the scope of the specified setting range. All genuine parts must be retained. The max. permissible thicknesses of the spacer washers in the front and rear axle control arms to change the camber angle are:

Furthermore, it is optional to hide the camber shims with aluminium tape. The trailing arm axle bearing points of the front and rear control arms must be left in the position in which they are delivered. Additionally, the screw positions of the trailing arms at the wishbone bearing points may not be modified. The wheelbase on the left and right sides of the Car must be 2,468 mm +/- 15 mm. The measuring points are the centres of the wheel hubs.

### 7.3. Anti-roll bars

The anti-roll bars are only permitted to be unhooked provided that one coupling rod of the respective rollbar is completely removed. Only the setting options for which the technical specifications have been provided are allowed to be used. The axial clearance of the anti-roll bars on the front and rear axles must be below 1.0mm. Designated shims shown in the spare parts catalogue are permitted to be used to compensate for the axial clearance.

### 7.4. Shock absorbers/springs

Only the factory-installed type Multimatic shock absorbers and H&R chassis springs in their original condition are allowed to be used. The following number is stamped on the bump stops of the rear vibration dampers: 9F1412303B The original delivery condition of the bump stops of the front and rear dampers must not be modified in any way.

#### Vibration damper

- Front: Pn: 9F1413031C
- Rear: Pn: 9F1513031C

#### Bump stop

- Front: Pn: 9F1412303B
- Rear: Pn: 9F1412303B

#### Main spring

- Front (260 N/mm): Pn: 9F1411105B
- Rear (300 N/mm): Pn: 9F1511105B

#### Helper spring

- Front (2N/mm): Pn: 9F1411411C
- Rear (2N/mm): Pn: 9F1411411C

### 8. Wheels

The use of any other wheels than the originally specified wheels is prohibited. All wheels must be fitted with original tyre pressure and temperature sensors. Only the use of the valve caps and valve inserts, provided by the Official Michelin Tyre Supplier – Kronos Tyres, are allowed. The rims are allowed to be painted. It is prohibited to paint or treat any functional surfaces (rim bed, contact area, wheel nut, mounting surface of the wheel). Rims may be repaired. The friction strips on the inside of the rim must stay functional and must not be treated in any way.

### 9. Bodywork and dimensions

#### 9.1. General description

- Lightweight bodywork with smart aluminium-steel composite construction
- Welded-in roll cage, in compliance with FIA Homologation Regulations for safety cages
- Front bonnet with two air intake ducts for cockpit ventilation and quick release fasteners
- Removable roof section in compliance with the latest FIA safety regulations
- Pre-equipped fixation point for centre safety net
- Pickup point for lifting device
- Modified and widened 911 GT3 fenders, Modified rear wheel arches
- Modified and widened 911 GT3 front-end with spoiler lip
- Modified 911 GT3 rear-end with integrated rain light, in compliance with FIA Homologation Regulations

#### 9.2. Lightweight exterior:

- Carbon-fibre-reinforced plastic doors with sport-design rear-view mirrors
- Carbon-fibre-reinforced plastic rear engine lid with quick release fasteners
- Carbon-fibre-reinforced plastic adjustable rear wing (11 positions)
- Polycarbonate door windows and rear side windows with ventilation openings
- Polycarbonate windows
- Rear underfloor with NACA ducts for brake and driveshaft cooling

#### 9.3. Modified 911 cockpit:

- Magnesium sub-frame in light weight design
- Ergonomic Driver-oriented centre console
- Switch mask with fluorescent lettering
- Steering wheel with quick release coupling, control panel and shift paddles
- Adjustable steering column with steering angle sensor
- Race bucket seat with longitudinal adjustment in accordance with FIA Standard 8862/2009
- Padding system in 3 sizes (delivery with size M)
- Shock absorbing roll cage safety cover for leg protection at Drivers footwell
- Six-point racing safety harness
- 110 litre fuel cell (FT3 safety fuel cell) and „Fuel-Cut-Off“ safety valve in accordance with FIA regulations



- Built-in air jack system (three jacks) with valve mountable on either side of the Car

#### 9.4. Water-based paint:

- Exterior: GT-silver-metallic (M7Z)
- Interior: GT-silver-metallic (M7Z) without clear lacquer finish
- Rims: Platinum semi-matt (OB5)

#### 9.5. Overall Car dimensions and overhangs:

Total length:	4,585 mm (180.51 inch)	+/- 15 mm
Track width of the front axle measured at the center of wheel hub plugs	1,885 mm (74,21 inch)	+/- 10 mm
Track width at the rear axle measured at the center of wheel hub plugs	1,885 mm (74,21 inch)	+/- 10 mm
Front overhang measured from the middle of the wheel of the front axle to the leading edge of the car (first point in the direction of the longitudinal axis, incl. front lip)	1,036.0 mm (40,79 inch)	+/- 15.0 mm
Rear overhang	1,081.0 mm (42,56 inch)	+/- 15.0 mm
Wheelbase	2,468 mm (97.16 inch)	+/- 15.0 mm

#### 9.6. External bodywork (including windows)

The delivery status of the bodywork has to be preserved.

##### 9.6.1. Windscreen

In addition to the original part, windscreen of the 911 GT3 Cup MY 2021 with the part number 9F1845099Y heated windscreens are permitted. The windscreen is allowed to be connected to the electrical system of the Car and the heating function is allowed to be used. To protect the windscreen and as a safety measure, 'tear-off' screens are allowed to be attached to the windscreen. Fitting will be checked during Technical Scrutineering and must be removed where applicable on request of the Technical Scrutineers.

##### 9.6.2. Side and rear windows

Only the genuine Porsche 911 GT3 Cup side and rear windows in their original version are permissible. Additionally, the rear window must remain fixed with the original type of fixing at all times.

#### 9.7. Cockpit

##### 9.7.1. Seat

The adaption of the seat by the addition of original Sabelt seat padding shown in green and blue in Attachment 4 is permitted. Each padding shape may only be used in the specific and correct location and direction as shown

in Attachment 4.

Additional padding at the head rest can only be added in accordance with the following conditions and the Technical Scrutineers discretion:

- The foam used for the padding must be the same material as the one used on the head rest by the seat manufacturer.
- The padding must be properly fixed to the seat.

Any addition or removal of material below the surface shown in black is forbidden.

Any modifications or addition of paddings outside of the prescriptions above must be presented to the Technical Scrutineers for approval.

A foamed seat insert, according to FIA Appendix J, Article 253-16, may be used as long as the insert is made of fireproof material, coloured in black. The use or change is subject to approval by the Series Organiser/Technical Scrutineers.

The original seat mounting (seat rails and bracket) must be retained and must not be modified.

The provisions of FIA International Sporting Code Appendix J Article 253 - 16 must be complied with at all times.

#### **9.7.2. Ventilation in the passenger compartment**

Only the factory-fitted ventilation pipe (NACA-intake on the front opening hood) is permissible for cockpit ventilation. The ventilation of the windscreen must not be affected. For additional ventilation of the passenger compartment only the existing original ventilation openings in the rear back windows are permissible.

The dimension of the NACA-intake port for cockpit ventilation at the center of the hood is permitted to be changed by taping.

#### **9.7.3. Safety Nets**

Every Car must be equipped with the after-sales safety nets as specified in the valid spare parts catalogue and mounted complying with the Porsche AG mounting instructions.

These can be found in the Technical Manual, Chapter 5.4

#### **9.8. Roll cage safety padding**

All Porsche GT3 Cup (type 992) must be equipped with the mandatory rollcage padding and food well foam defined in the current Technical Manual and Spare Parts Catalogue of the Car.

#### **9.9. Additional roof hatch accessories**

The Car has an opening in the roof in order to make using the KED system easier should it become necessary to rescue the Driver. The roof hatch is located directly above the Driver. The roof hatch is connected to the roof with 7 livelocks which must be accessible at all times (no foiling or painting of live locks is permitted).

### **10. Aerodynamic devices**

Masking the radiator grilles is prohibited. Furthermore, entrants are allowed to tape over the full area of the headlight and day/turn signal light lenses with uncoloured transparent Heli tape, without thereby taping over a slot in the bodywork. Apart from the above, taping over of any slots in the bodywork, wings or other permanent parts, joints and openings is not allowed.

It is mandatory to have a strip of tape of maximum 85cm length, positioned as per the tape in the photo below, to cover the slot between the front bumper and bonnet. The strip of tape is optional for the practice and qualifying.



Apart from the above, taping over of any slots in the bodywork, wings or other permanent parts, joints and openings is not allowed.

The original position of the wing section is permitted to be changed within the specified scope for adjustment provided by the Technical Manual.

There are 11 adjustment positions: from 4° to 14°. Each adjustment position, according to the regulations, is defined by the bolt holes with matching markings as shown in the Technical Manual. All mounting bolts (left- and right-wing support, front and rear bolt) must use the same corresponding bolt holes.

The use of the front air scoop (Pn:9F1.407.811 and Pn: 9F1.407.812) is mandatory for each event.

If a session is declared as a wet session it is permitted to close all slots on the rear side windows with transparent heli tape. In case of rain, the slotted side rear windows may be taped off with any kind of tape in Parc Ferme after the permission of the Technical Scrutineer.

Any alteration or amendment outside the above set parameters will render the car non-compliant with the Technical Regulations and may be subject to penalties from the Stewards.

### **11. Electrical equipment**

From the moment the Cup Car enters the race track or pitlane to the end of the "Parc Fermé" during qualifying and racing, only the Series Organiser and personnel nominated by the Series Organiser are allowed to connect laptops/computers to the Cup Cars. The word 'track' is understood as the part of a circuit that is clearly demarcated to race. For the same period, no external connection (also wireless) may be made between the Car and any external equipment other than the Cars equipment to read from the antennas of the tyre pressure monitoring system. It is not permitted at any time for any Competitor to read any sensors with any equipment, which are not allocated to the Competitor's own team. Any breach of this regulation may result in the Car being disqualified from qualifying or racing.

#### **11.1. General description**

- 10,3" Porsche color display
- Porsche logger
- Porsche power box
- Fire extinguishing system (extinguishing agent: Novec gas)
  
- Lightweight Battery 12 V, 60 Ah (LiFePO4), leak-proof, placed in the co-Driver foot well

- Alternator 175 A
- Fan in light weight design
- Single-arm wiper with direct drive (intermittent and continuous operation)
- Digital touchpanel with multi-color back light.
- Three additional center console switches for additional consumers,
- Data connection (Data logger, Video system)

It is allowed to install the following battery charging cable from Manthey-Racing to charge and “wake up” dead batteries:

MTH000116A – AS Charging cable

The loom must be fitted according to the latest mounting instructions.

No other additional charging loom is permitted.

### **11.2.LED Lighting system:**

- Main headlight
- LED daytime running light
- LED rear lighting system and rain light in compliance with the latest
- FIA Homologation Regulation

### **11.3.Optionally, the usage of the following electrical equipment is permitted:**

AS Sensor GPS (9F2927748)

## **12. Fuel circuit**

Only the original fuel system is permitted in combination with the after-sale defueling kit. It is described in the current Technical Manual as “option defueling-kit standard tank”. All Cars must be equipped with this defueling kit. All parts shown in the spare parts catalogue indicated for long distance races are prohibited.

The running of the Car using the service position of the fuel pumps is prohibited, as long as there is no technical issue with the system. The system may not be used with any of the pumps switched to service position for more than one lap.

## **13. Lubrication system**

### **13.1.Lubricants**

#### **13.1.1. Engine:**

Mobil 1 ESP X3 0W40 engine oil is mandatory. All additives are prohibited.

#### **13.1.2. Transmission:**

Mobilube 1 SHC 75W-90 transmission oil is mandatory. All additives are prohibited. No less than the minimum quantity of transmission oil as specified in the Technical Manual must be used at all times during the Event.

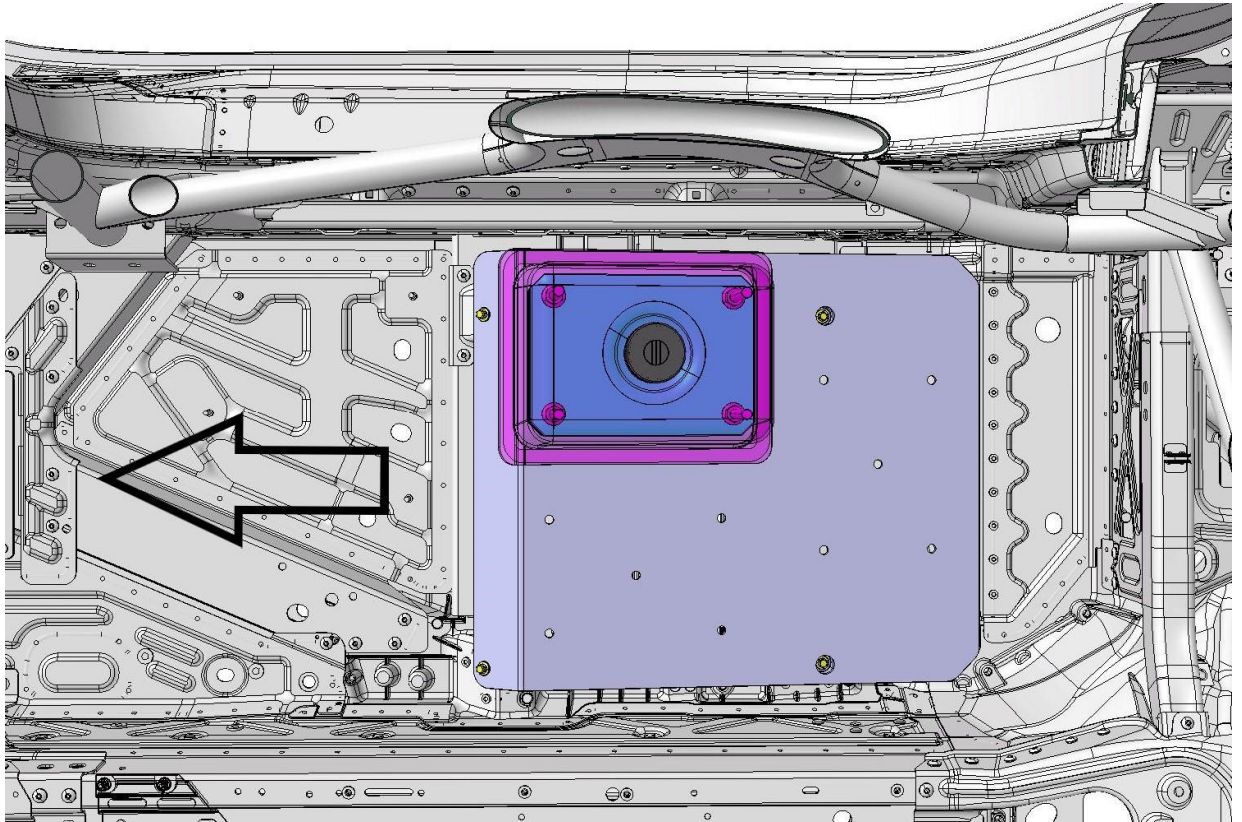
**Attachment 1: Ballast weights**

Auxiliary weights part numbers:

Part	number	alternative number (previous model)
AUXILIARY WEIGHT 2KG/6MM	9F1801141	99150484800
AUXILIARY WEIGHT 3,5KG/10MM	9F1801141A	99150484801
AUXILIARY WEIGHT BIG 6,8KG/20MM	9F1801141B	99150484802
COVERING AUXILIARY WEIGHT	9F1801575	9915048659B
KNURLED NUT COVERING	WHS001903	9915048529B

**Attachment 2: Differential lock ramp breakover angle**

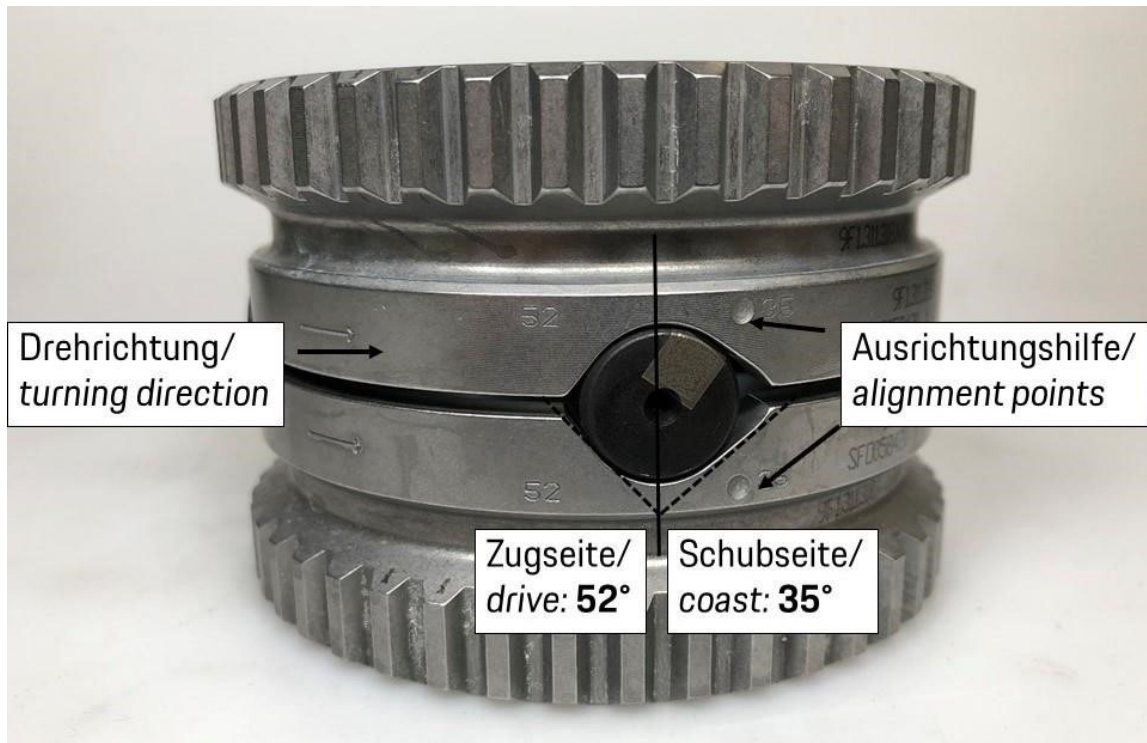

**Attachment 3: Differential design**

The differential is fitted with 12 friction surfaces (12FF) as standard. The arrangement of the parts is shown in detail in the image:

PP = Pressure Plates  
CD = Clutch Discs  
FF = Friction Plates

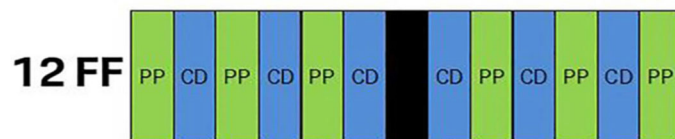

**Attachment 4: Seat**

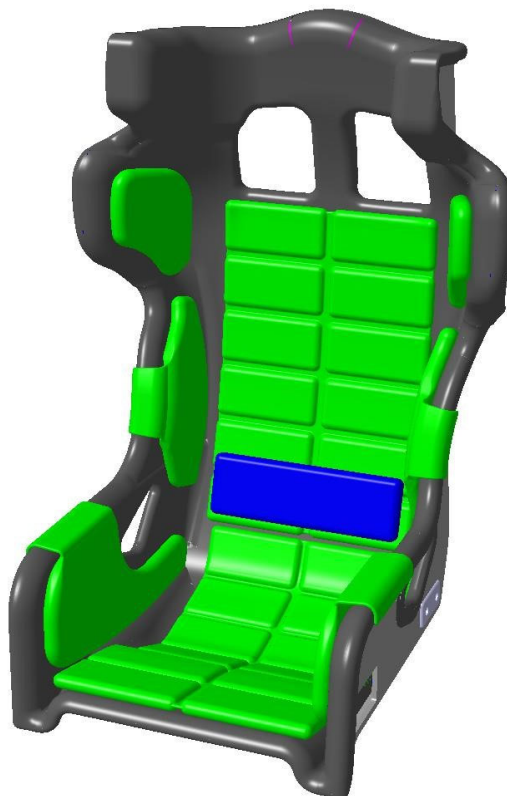

**Attachment 5: Timing transponder (Mandatory for all competing Cars)**

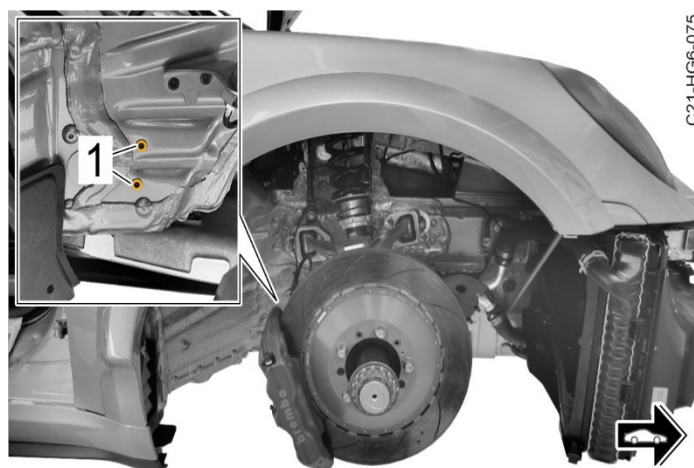

C21-HG6-075

**Attachment 6: Ride height measuring positions**

**Positionen Fahrhöhenmesspunkte/ ride height measuring positions**

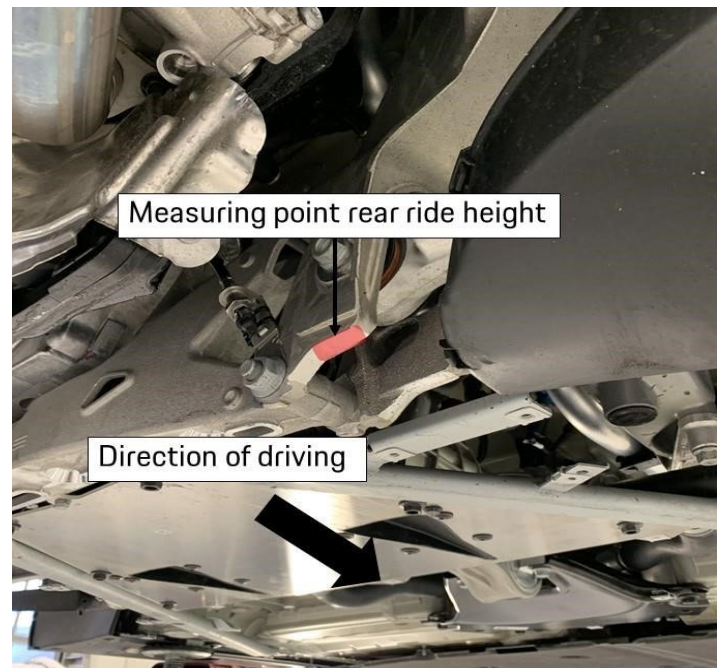
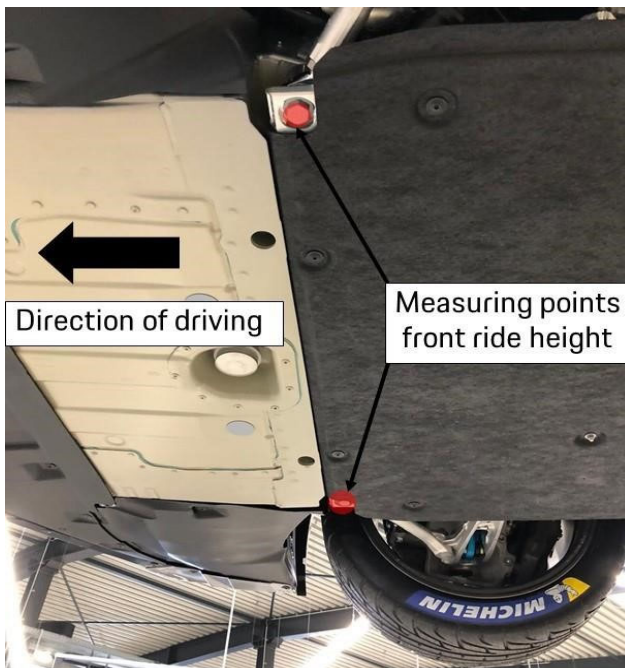
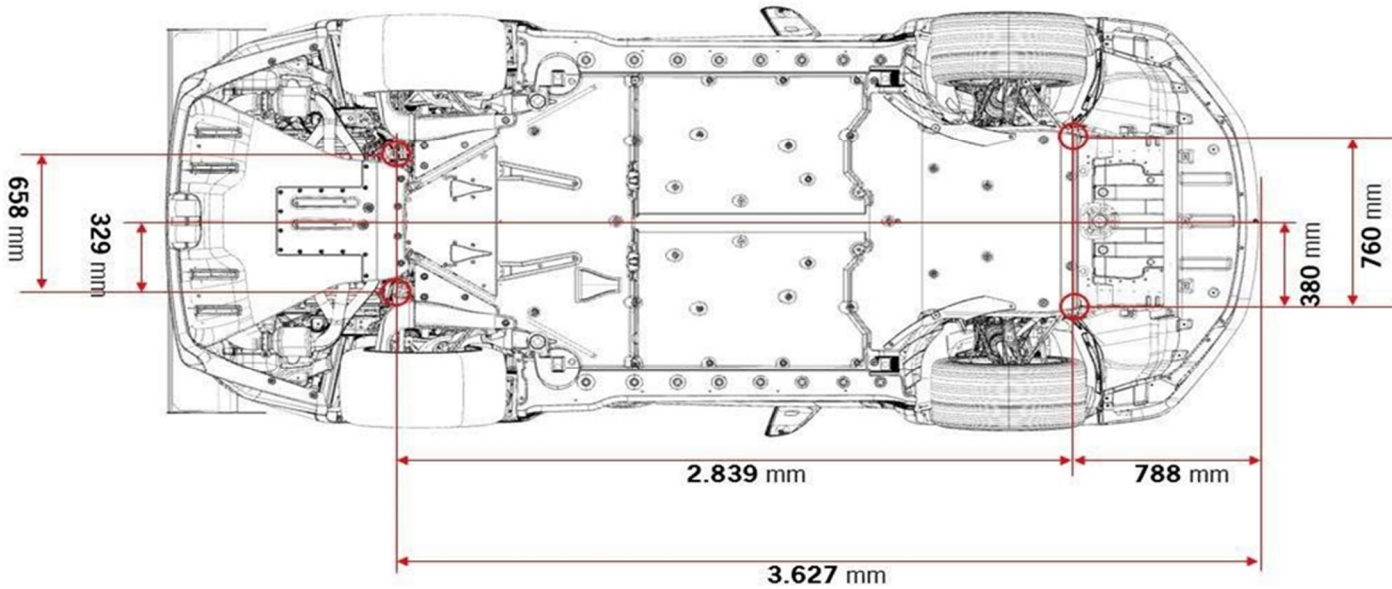



## **C.2.0: "CAYMAN CLUBSPORT" Tech. Regulations**

In Part C are the general rules described for the model Porsche 718 Cayman GT4 Clubsport, type 982 and Porsche 718 Cayman GT4 RS Clubsport, type 982. The concerning Cars must fully comply with these Regulations. The Cayman GT4 from series production is used as the basis for this Car. The Cars must meet the technical specifications of these Regulations and Appendix J of the International Sporting Code in full.

### **1. Accepted Cars**

- Porsche Cayman GT4 RS Clubsport
- Porsche Cayman GT4 Clubsport, 'Trophy'-spec
- Porsche Cayman GT4 Clubsport MR, 'SRO GT4 / MR'-spec

### **2. Specification**

The base models available in 2 configurations, the 'Track day' and the 'Competition'. The Cayman in 'Competition' configurations is allowed to do compete in races. In the PSCB the 'Competition' version is upgrade to a 'Trophy' specification. To increase the Drivers' safety, to make the race Car more reliable.

The 'Trophy' spec is developed for the VLN series organised by Manthey Racing, The 'GT4' spec is developed for SRO GT4 series. In the Porsche Sprint Challenge Southern Europe, the Porsche 718 Cayman GT4 CS (982) must be fully compliant with one of the two, 'Trophy' or 'GT4' specifications. All race Cars must be fully equipped according the Manthey Racing spare parts catalogue from the eligible Car following the 'spec'. In the above mentioned spare parts catalogue is made a subdivision, indication for individual parts or group of parts if it belongs to the 'Trophy' spec or 'GT4' spec.

### **3. Principles of the Technical Regulations in accordance with**

- Art. 277 of Appendix J (ISG from the FIA)
- These Technical Regulations
- Technical manuals of the eligible Cars
- Technical information of Porsche AG (Porsche Motorsport: PMRSI)
- Spare parts catalogues of the eligible Cars (Porsche Motorsport & Manthey Racing)
- General provisions, definitions and clarifications regarding the technical rules of the ASN
- Wiring diagrams of the eligible Cars
- GT4 homologation, depending on the specifications of the Car

### **4. Exclusion of a Porsche 718 Cayman GT4 Clubsport, type 982**

The organiser has the right to exclude a Car from competing during an Event when the Car isn't repaired correctly after an incident. It doesn't matter if this incident took place during a Porsche Sprint Challenge Southern Europe Event, unofficial test drive session or other championship Events. The arguments could be: Safety, in the broadest sense of the word:

- Car is in violation with these Technical Regulations
- Any reason that Porsche AG (in the broadest sense of the word) defines by any medium.
- Damaged roll cage
- Repaired roll cage without certificate.

## 5. Replacement and loss of Car parts

In case of a loss of coolant, the final weight of the Car may be only determined by draining all remaining coolant liquid (from engine, coolant reservoir, all radiators, all coolant hoses and connectors) and adding, 25 kg, to the measured weight of the Car.

## 6. Ground clearance measuring point

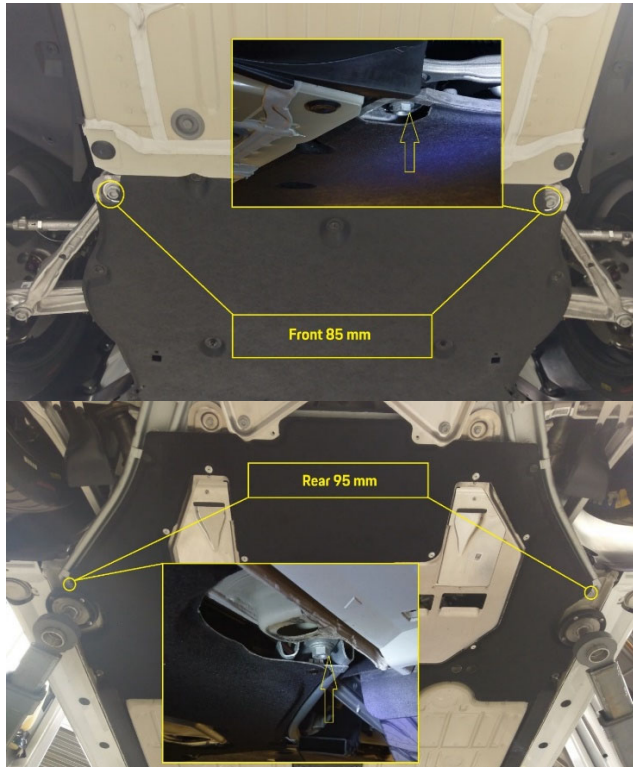

Example : Porsche Cayman GT4 Clubsport 'Trophy Spec'

## 7. Control Devices and Software Versions

Software and hardware for the control electronics can be inspected by the Series Organiser or the technical delegate at any time, and must always meet the specification defined in the current version of the user manual. If this is not the case, this can be reported to the Stewards of the Event and the Series Organiser. The Series Organiser may, at any time, update or replace the software versions or the hardware for the control devices.

## 8. Safety equipment

The Cars must contain the following safety equipment. The article numbers refer to the current Appendix J of the ISC, unless stated otherwise.

- Lines and pumps in compliance with Art. 253.3.1 and 253.3.2 and accordingly Art. 259.6.2
- Oil catch tank in compliance with Art. 259.7.4
- Fuel cell ventilation in compliance with Art. 253.3.4
- Double circuit braking system in compliance with Art. 253.4
- Additional safety fastener in compliance with Art. 253.5
- Safety belts in compliance with Art. 253.6 and accordingly Art. 259.14.2.1
- Manual extinguisher in compliance with Art. 253.7.3
- Fire extinguishing system in compliance with Art. 253.7.2 and accordingly Art. 275.14.1
- Safety cage in compliance with Art. 253.8

- Safety cage in compliance with Art. 253.8 (Appendix J 1993)
- Safety cage in compliance with Art. 277
- Rear view mirror in compliance with 253.9 and accordingly Art. 275.14.3
- Towing-eye/device in compliance with Art. 253.10 and accordingly Art. 259.14.6
- Safety foil on the windows in compliance with the DMSB prescriptions
- Windshield made of laminated glass
- Door nets in compliance with Art. 253.11 or with the DMSB prescriptions
- Additional safety fixing devices for windshield in compliance with Art. 253.12
- General circuit breaker in compliance with Art. 253.13
- Safety fuel tank in compliance with FIA standard FT3/FT3-1999 and accordingly FT5 in compliance with Art. 253.14 and accordingly 259.6.3
- FIA homologated non-return valve in the filler neck in compliance with Art. 253.14.5
- Firewall in compliance with Art. 253.15 or Art. 259.16.6 respectively
- Seats and attachments as defined in the spare parts catalogue
- FIA homologated Driver seat in compliance with Art. 253.16
- Headrest in compliance with Art. 259.14.4
- Rear light in compliance with Art. 275.14.5
- Reverse gear in compliance with Art. 275.9.3
- Prohibition of pressure control valves in compliance with Art. 253.17
- Article 277
- In compliance with the Appendix K to the ISC

**8.1. Wheels combinations**

	Porsche Cayman GT4 RS Clubsport	Porsche Cayman GT4 Clubsport – all types
<b>Front</b>	9F2601017A	9F2601017A
<b>Rear</b>	9F2601075A	9F2601075A

### **C.2.1.: Specific Tech. Regulation according to the model Porsche Cayman GT4 RS Clubsport**

According to the GT4 Homologation of the Car, with the exceptions mentioned in these technical regulations:

- Tyres
- Min. ground clearance
- Min. Car weight
- Max. camber shims
- Exhaust system

### **C.2.2.: Specific Tech. Regulation according to the model Porsche Cayman GT4 Clubsport, 'SRO GT4 / MR'-spec, Type 982, ('19- '20)**

According to the GT4 Homologation of the Car, with the exceptions mentioned in these technical regulations:

- Tyres
- Min. ground clearance
- Min. Car weight
- Max. camber shims

### **C.2.3.: Specific Tech. Regulation according to the model Porsche 718 Cayman GT4 Clubsport, 'Trophy'-spec, Type 982, ('19- '20)**

In C.2.2. are the add. regulations described only valid for the model Porsche 718 Cayman GT4 Clubsport, **Type 982, (MY '19-'20)**.

#### **1. General Car description**

Porsche 718 Cayman GT4 Clubsport (type 982), MY 2019-2020

Concept: Single-seater, near-standard production-based race Car, not road homologated.  
Based on the Porsche Cayman GT4

#### **2. Engine**

- Aluminium six-cylinder rear-mounted boxer engine with rigid mounting
- 3,800 cc; stroke 76.4 mm, bore 102,7 mm
- Max. power: 313 kW (425 hp) at 7,500 rpm
- Max. rpm: 7,800 rpm
- Max. torque: 425 Nm at 6 600 rpm
- Compression ratio: 12.5:1
- Racing optimised water cooling with thermal management for engine and gearbox
- Four-valve tech., adjustable camshaft phasing, variable valve timing VarioCam Plus
- Sequential multi-point fuel injection
- Fuel quality: minimum 98 octane, unleaded
- Dry sump lubrication
- Electronic engine management (Continental SDI 9)
- 100-cell metal catalytic converter complying with DMSB specifications
- Rear silencer with central tailpipes
- Variable intake system with adjustable resonance butterflies
- Twin pipes sport exhaust system featuring two central tailpipes

#### **3. Power transmission (gearbox/differential lock)**

- Rear wheel drive
- Rigidly mounted Porsche six-speed PDK- gearbox (DCT, dual clutch transmission)
- Limited slip differential optimised for racing
- Dual mass flywheel



Obligatory 10mm spacers must be installed between the transmission and the drive shaft flanges in conjunction with mandatory mounting material.

- Spacer sleeve PPN.: 9F2501199
- Plate link shaft PPN.: 9P1501375
- ZYL-SHR M10x55 4762 12.9 B110 PPN.: 90006708701

#### 4. Brakes

##### Front axle:

- Six-piston aluminium racing brake calipers in mono-bloc design with "anti-knock-back" piston springs
- Ventilated and grooved steel brake disc 380 mm diameter with aluminium disc bells  
PPN.: 9F2615283 (FL) PPN.: 9F2615284 (FR)
- Racing brake pads  
PPN.: 9913519428B (Endurance)
- Optimized brake cooling duct layout

##### Rear axle:

- Four-piston aluminium racing brake calipers in mono-bloc design with "anti-knock-back" piston springs
- Ventilated and grooved steel brake disc 380 mm diameter with aluminium disc bell  
PPN.: 9F2615583 (RL) PPN.: 9F2615584 (RR)
- Racing brake pads  
PPN.: 9F2615117A (Endurance)
- Optimized brake cooling duct layout

A knock-back spring must be installed in each case under each brake piston of all brake calipers. External thermal or chemical treatment of these springs is prohibited.

PPN.: 9913519638A (Front) PPN.: 9913529638A (Rear)

The integrated driving stability system PSM (includes ESC and TC) is specially set up for use on the race track and must not be changed by the Competitor. The system can be fully switched off.

#### 5. Steering (steering wheel/hub extension)

Steering is defined in the parts catalogue and must be assembled without any changes.

#### 6. Wheel suspension

##### **6.1. General description front axle**

- McPherson suspension strut, adjustable in height, wheel camber and track
- Forged suspension links:
  - Optimised stiffness
  - Double shear mounting
  - High-performance spherical bearings
- 5 bolt wheel hubs
- Racing shock absorbers, non-adjustable
- Reinforced track rods
- Electromechanical power steering with variable steering ratio
- Anti-roll bar, 3-hole design

##### **6.2. General description rear axle**

- McPherson suspension strut
- Forged suspension links: Optimised stiffness, double shear mounting, high-performance spherical bearings

- 5 bolt wheel hubs
- Racing shock absorbers, non-adjustable
- Adjustable blade-type anti-roll bar

### 6.3. Wheelbase

The trailing arm axle bearing points of the front and rear control arms must be left in the position in which they are delivered. Additionally, the screw positions of the trailing arms at the wishbone bearing points may not be modified. The wheelbase on the left and right sides of the Car must be 2472 mm (+/- 15 mm). The measuring points are the centres of the wheel hubs.

### 6.4. Anti-roll bars

The anti-roll bars are allowed to be unhooked, for this purpose the stabiliser link that is unhooked must be removed. Only the setting options for which the technical specifications have been provided are allowed to be used.

### 6.5. Shock absorbers/springs

Only the following combinations are allowed. Spring combinations may only be completely installed as stated underneath. Standard spring combination (130 / 150N / mm) must not be combined with strut combination option 1 (110 / 120N / mm).

<b>'Trackday' specifications – STANDARD (Porsche Motorsport)</b>			
<b>Front</b>		<b>Rear</b>	
Shock absorber	9F2412019	Shock absorber	9F2512019
Main spring 130-140	9F2411105	Main spring 150-170	9F2511121
Auxiliary spring 10-60-80	9813435378A	Auxiliary spring 10-60-80	9813435378A

<b>'Competition' specifications – STANDARD (Porsche Motorsport)</b>			
<b>Front</b>		<b>Rear</b>	
Shock absorber	9F241202(3/4)A	Shock absorber	9F2512020A
Main spring	9F2411105A	Main spring	9F2511121A
Auxiliary spring	9813435378A	Auxiliary spring	9813435378A

<b>'Trackday' specifications – OPTION 1 (Manthey Racing)</b>			
<b>Front</b>		<b>Rear</b>	
Shock absorber	9F2412019	Shock absorber	9F2512019
Main spring 110-140	MTH343533	Main spring 120-170	MTH333533A
Aux. spring 10-60-80	MTH343538	Aux. spring 3-60-80	MTH343537A
Bump stop	65210488	Bump stop kit	MTH072300

### 7. **Bodywork**

#### 7.1. General description

- Lightweight bodywork with intelligent aluminium-steel composite construction
- Welded-in roll cage, in compliance with FIA Homologation Regulations for safety cages
- Front bonnet with quick release fasteners
- Rear deck with quick release fasteners
- Fixed rear wing with "swan neck" mount made of natural-fibre composite materials, including the side blades, black aluminium wing supports with integrated carbon fibre Gurney flap
- Six-point safety harness
- Driver and co-Driver doors of natural-fibre composite materials
- Roof including escape hatch, certified according to FIA Art. 275a
- Provision for safety net
- FIA certified towing loops
- Three-piston air jack
- Recaro race bucket seat with longitudinal adjustment and padding system, adjustable to the individual needs of the Drivers (in accordance with FIA Standard 8862/2009 – the latest FIA requirements)
- Motorsport centre console with enhanced functionality and adapted usability
- 115 liter FT 3 Safety cell with 'Fuel cut off' safety valve according FIA

#### 7.2. External Bodywork (including Windows)

✕ The windows of the Driver and passenger door, the rear side windows and the rear window must be covered with safety foil as described in the parts catalogue and the user manual.

The outside of the windscreen may also be covered with a clear safety film/rip-off film (not coloured). The laminated glass front windscreen may optionally be replaced by a polycarbonate windscreen.

MTHPN.:MTH541911

In general, it is not permitted to close or glue openings or joints. In the case of provisional repairs during the Event, joints or openings in the direct vicinity of the damage may be covered with adhesive tape if this is necessary due to a lack of time. The technical delegate will decide on whether the repairs are permissible.

#### 7.3. Cockpit

No individual ventilation hoses are permitted. A drinks unit may be fitted if this is a permanent attachment and the mounting points can withstand an acceleration of up to 25G. It is at the technical delegate's discretion to assess whether he believes the attachment used is sufficient. The pedals may not be changed. This does not include adding a film with increased friction. The seat, seat rails and belts must correspond to the parts catalogue. The series steering column adjustment mechanism is maintained. All covers in the cockpit must be used as described in the parts catalogue.

### 8. **Electrical Equipment**

The Cayman GT4 Clubsport has a tyre pressure system (RDK) as a standard feature. It is mandatory to use the RDK sensors during the Event. If the race organiser should require additional systems that result in data transfer, this must be approved by the technical delegate. Only the sensors described in the parts catalogue may be used.

Optional systems:

Additional lighting kit

MTHPN.:TBA

Charging cable  
Voltage supply electronic

PPN.: 9F0051763B  
PPN.: 9816106898A

### 9. Air Jack System

The air lifting system including the air lance system is mandatory.

MTHPN.:MTH583004A

The positions of all the components that are relevant for the system, such as the air lance connector mounted on the Car, may not be changed. In addition, regulations stipulate that, after the air lance is removed from the air lance connector, the pressure must remain in the lifting system. Only the operation of the valve mounted on the Car must lead to air being released and the jacks being pulled-in.

### 10. Water-based paint

- Exterior: white C9A
- Interior: white filler-coat, no clear-coat finish

### 11. Overall Car dimensions and overhangs

- The overall length of the Car is 4456mm.
- Total width: 1778 mm
- Total height: 1238 mm
- Wheelbase: 2,472 mm +/- 15 mm

### 12. Lubrication system

Engine: Mobil 1 ESP X3 0W-40

Transmission: Clutch oil (ATF): Pentosin FFI 3

Final drive: 75 W 90 Mobilube PTX

The above mentioned oil types are mandatory. All additives are prohibited.

### 13. Fuel system

A safety fuel tank according to FIA standard FT3-1999 by Art. 253.14 is installed. The maximum fuel volume of 115 litres is made up of the internal volume of all fuel-carrying components, including e.g. the filler pipe or the filler neck. Only the participant is responsible for ensuring that the maximum permitted volume is not exceeded. It is permitted to reduce the volume of the fuel tank using volume displacers/displacement balls. Two different refuelling systems are allowed. One of those two system must be installed. Only original parts specified in the Porsche Motorsport and/or Manthey Racing catalogue can be used.

#### 13.1. 'Trophy' specifications tank plate (fuel gun)

This system developed for refuelling with fuel gun or dumping barrels. The tank refuelling plate for fuel gun use must be installed with the bonnet with rounded whole, finished with carbon fibre ring.

- 'Trophy' spec refuelling plate: MTHPN.:MTH201615
- Bonnet made of sheet metal, with round hole: MTHPN.:MTH823310

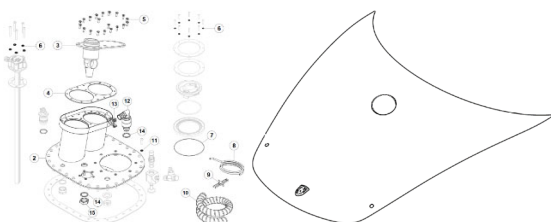



### 14. **Mandatory rework**

#### 14.1. **Engine air ducts mesh:**



To protect the two engine air ducts and the engine compartment ventilation system from sucking debris, the installation of the protection meshes into the air intakes in the body sills is mandatory.

MTHPN.:MTH541561 (Left)

MTHPN.:MTH541562 (Right)

#### 14.2. **Safety nets:**



It is mandatory to use the after sales safety nets as specified in the valid spare parts catalogue and mounted complying with the Porsche AG mounting instructions. MTHPN.:MTH801110

#### 14.3. **Safety foam Driver's door:**



It is mandatory to use the after sales safety foam mounted in the Driver's door as specified in the valid spare parts catalogue and mounted complying with mounting instructions. MTHPN.:MTH531750

#### 14.4. **Brake pressure switch:**



Valid for all Type 982 including the 'GT4'-spec. The brake pressure switch mounted on the front axle brake master cylinder must be changed to the latest spec. PPN: 9F1907457

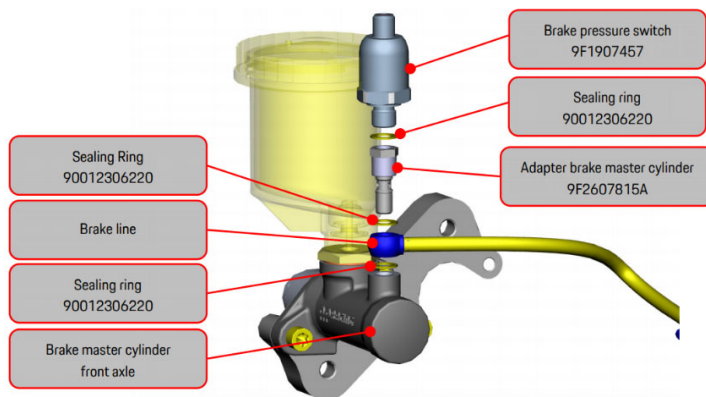

#### 14.5. **Roll over valve**



Valid for all Type 982 including the 'GT4'-spec. The rollover valve mounted on the fuel tank must be changed to the latest spec. PPN: 9F0201741G

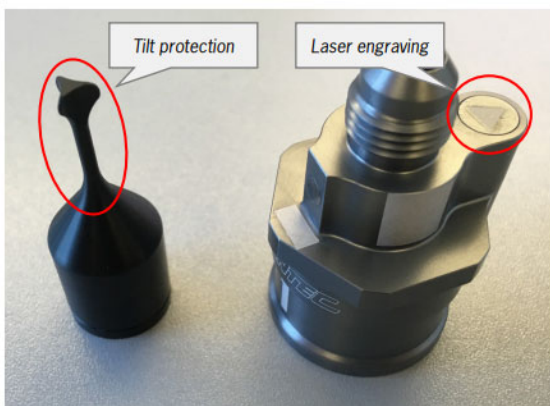

Fig. 3. New design floater with tilt protection and ROV housing upper part

**PORSCHE**

**SPRINT CHALLENGE  
SOUTHERN EUROPE**



El presente REGLAMENTO queda  
aprobado a efectos deportivos.

Madrid,

**20-01-23**

Fdo.: Paloma Izquierdo  
Directora Deportiva

