



TECHNICAL REGULATIONS

DD2 MASTER / DD2 / SENIOR MAX / JUNIOR MAX



IK kartódromo internacional algarve



PORTIMÃO

PORTUGAL

NOV 19 – 26

Supported by:



© 2022 BRP-Rotax GmbH & Co KG. All rights reserved. ® and TM and the BRP Logo are trademarks of Bombardier Recreational Products Inc. or its affiliates. All other trademarks are the property of their respective owners.

VISA FPAK N° 1653T/KEEx/2022 Emitido em 26/10/2022



RMCGF 2022 – JUNIOR MAX / SENIOR MAX / DD2 / DD2 MASTER

| | |
|--|-----------|
| 1. RMCGF 2022 CATEGORIES..... | 3 |
| 2. EQUIPMENT..... | 3 |
| 2.1. AMOUNT OF EQUIPMENT | 3 |
| 2.2. CHASSIS, BRAKE SYSTEM, BODYWORK | 3 |
| 2.3. TIRES | 5 |
| 2.4. ENGINES..... | 6 |
| 2.5. RETURN OF EQUIPMENT | 6 |
| 2.6. DATA ACQUISITION..... | 6 |
| 2.7. SAFETY EQUIPMENT | 6 |
| 2.8. FUEL/OIL..... | 6 |
| 2.9. ADVERTISING ON ENGINES | 6 |
| 3. MODIFICATIONS, LEGAL ADDITIONS, NON-TECH ITEMS, MEASUREMENTS..... | 7 |
| 3.1. MODIFICATIONS..... | 7 |
| 3.2. LEGAL ADDITIONS..... | 7 |
| 3.3. MEASUREMENTS..... | 7 |
| 4. TECHNICAL SPECIFICATION (OUTSIDE THE ENGINE AND CARBURETOR SEAL) FOR ROTAX KART ENGINES..... | 7 |
| 4.1. BALANCE DRIVE..... | 7 |
| 4.2. CENTRIFUGAL CLUTCH..... | 8 |
| 4.3. PRIMARY DRIVE (125 MAX DD2): | 9 |
| 4.4. GEAR SHIFTING (125 MAX DD2)..... | 9 |
| 4.5. EXHAUST VALVE (125 SENIOR MAX AND 125 MAX DD2)..... | 10 |
| 4.6. IGNITION SYSTEM | 11 |
| 4.7. BATTERY, BATTERY FIXATION | 13 |
| 4.8. INTAKE SILENCER | 13 |
| 4.9. CARBURETTOR | 14 |
| 4.10. FUEL PUMP, FUEL FILTER | 14 |
| 4.11. RADIATOR..... | 15 |
| 4.12. ENGINE COOLANT..... | 16 |
| 4.13. EXHAUST SYSTEM | 16 |
| 4.14. ADDITIONAL SEAT SUPPORT (125 MAX DD2) | 17 |
| 5. PERMITTED ADJUSTMENTS TO THE CHASSIS, ENGINE, CARBURETTOR AND DRIVE TRAIN OPTIONS | 18 |
| 125 JUNIOR MAX – SODIKART | 18 |
| 125 SENIOR MAX – SODIKART | 19 |
| 125 MAX DD2 – BIRELART | 20 |
| 125 MAX DD2 MASTERS – IPKARTING PRAGA..... | 21 |

The Competition shall be run in accordance with the RMC GF 2022 Technical Regulations and official Bulletins and:

- ROTAX MAX CHALLENGE GRAND FINALS 2022 Sporting Regulations and the official Bulletins
- ROTAX MAX CHALLENGE GRAND FINALS 2022 Supplementary Regulations
- CIK/FIA Karting Technical Regulations and official Bulletins

The Organizer of the event reserves the right to issue modifications to the Technical Regulations, that will be published as Official Bulletins.

The English language is the official version.

Headings in this document are for ease of reference only and do not form part of these Technical Regulations.

1. RMC GF 2022 CATEGORIES

- 125 Junior MAX
- 125 Senior MAX
- 125 MAX DD2
- 125 MAX DD2 Masters

2. EQUIPMENT

The only equipment – complete kart and tires – allowed during the event will be provided on a loan basis, by the organizer and must be in accordance with these Regulations and its Appendices.

2.1. Amount of equipment

2.1.1. One chassis, one engine and tires according to article 2.3

2.1.2. Each driver will receive a complete kart draw by raffle (chassis and engine) - on a loan basis for the whole event -, according to the official time schedule.

2.1.3. The driver cannot refuse the vehicle that has been raffled.

2.1.4. No modification is allowed unless specified in the RMC GF Technical Regulations 2022 and its Appendices.

2.1.5. During the event drivers/competitors are not allowed to take the kart, or any part of it (except the battery and battery charger), outside the track facilities.

A Technical Scrutineer may check at any time during the event if the vehicle is complete and all components are present.

If any element of the vehicle is missing, the driver will have the following penalties applied:

- Prior to qualifying, the driver will receive a 10 places penalty on the starting grid for all the qualifying heats.
- Prior to any race, the driver will receive a penalty of 10 seconds for the next race in which he will take part.
- In the event of a repeated infringement, the driver will be disqualified from the event.

2.1.6. Any equipment that was detected as missing must be controlled by the Technical Scrutineer and can also be replaced.

2.2. Chassis, brake system, bodywork

2.2.1. Single brand chassis per category, defined by tender. The brand for each category is:

- 125 Junior Max: Sodikart
- 125 Senior Max: Sodikart
- 125 Max DD2: BirelART
- 125 Max DD2 Master: IPKarting PRAGA

2.2.2. Chassis are randomly assigned (on a loan basis for the time of the event) to drivers, registered and routinely checked/scanned by means of the Rotax EMS (Event Management System).

2.2.3. Chassis, brake system, bodywork and Rear Wheel protection system must have a valid CIK homologation and must be in accordance with RMC GF Technical Regulations 2022 and its Appendices

2.2.4. Front brakes are not allowed in Rotax 125 Junior Max and 125 Senior Max categories.

2.2.5. The Chief Scrutineer may allow some changes on the chassis, e.g. in case the height of a driver will not allow him/her to fit properly in the kart.

2.2.6. Every chassis is marked with a chassis seal with a unique serial number (barcode)

2.2.7. During the event, and in case of an accident, the driver can only change one time the chassis (frame) after the authorization of the Technical Scrutineers. In this case the frame and the other needed parts must be paid for in advance (prices will be defined in the manufacturers price list prior to the event).

2.2.8. Seat

- Original seat as supplied by the respective chassis supplier is legal to be used only.
- It is the Driver / Entrant responsibility to mount the seat in accordance with the regulations.
- All fixation screws and nuts for the seat must be mounted and tightened at all times.
- Additional seat stays (supports) must be either fitted and tightened or removed from the chassis.
- Seat supports welded on the frame must not be bent except when authorized by the chassis manufacturer.
- Lead must be fitted to the seat only.

2.2.9. Axles: Only the original rear axle as supplied by the respective chassis supplier is legal to be used.

- Cutting the rear axle is not allowed.
- Fitting anything into the rear axle is not allowed!
- Stub axle adjustment must not be covered.

2.2.10. Stabilizer and sleeves must be either fitted and tightened or removed from the chassis.

2.2.11. Steering wheel can be mounted in any height positions to fit the driver using the standard or optional material as supplied/defined by the manufacturer. Steering shaft cannot be cut.

2.2.12. Floor tray: All screws and nuts must be fitted and tightened at all times.

- A data acquisition sensor must be mounted to one of the fixation screws of the floor tray.
- Drilling a hole/s in the floor tray is not allowed.
- To remove the foot rest is an allowed adjustment.

2.2.13. The 2 supports for the rear bumper must be mounted tight to the frame at all times. Screws of the rear bumper may be loose to enable a lateral movement of the rear bumper only.

2.2.14. Only original brake pads as supplied by the chassis manufacturer for the Grand Final are legal to be used.

2.2.15. It is only allowed to use the parts, including rims, originally supplied by the chassis manufacturer.

2.2.16. Legal optional parts:

- Shorter pedals.
- Shorter brake rod.
- Angled steering wheel boss.
- Adjustable steering wheel boss.

2.2.17. Front fairing

- a) The use of a homologated Front Fairing and of the homologated Front Fairing Mounting Kit of the bodywork homologation period 2015 – 2020 is mandatory for all categories, in accordance with CIK Specific Prescriptions, article 30 and CIK Technical Drawing No 2d.
- b) Appropriate fairings and mounting kits will be provided to Entrants/Drivers with each kart and are the only components which may be used.
- c) The provisions of CIK Specific Prescriptions, article 30 regarding mounting, installation, checking, reporting of breaches and application of penalties will be applied in full.

2.3. Tires

2.3.1. Type:

125 Junior MAX

| | | | |
|-----|----------------------|----------------------|---------------------|
| Dry | Mojo D2XX CIK Option | front 4.5 x 10.0 – 5 | rear 7.1 x 11.0 – 5 |
| Wet | Mojo W5 CIK | front 4.5 x 10.0 – 5 | rear 6.0 x 11.0 – 5 |

125 Senior MAX

| | | | |
|-----|-------------------|----------------------|---------------------|
| Dry | Mojo D5 CIK Prime | front 4.5 x 10.0 – 5 | rear 7.1 x 11.0 – 5 |
| Wet | Mojo W5 CIK | front 4.5 x 10.0 – 5 | rear 6.0 x 11.0 – 5 |

125 MAX DD2

| | | | |
|-----|-------------------|----------------------|---------------------|
| Dry | Mojo D5 CIK Prime | front 4.5 x 10.0 – 5 | rear 7.1 x 11.0 – 5 |
| Wet | Mojo W5 CIK | front 4.5 x 10.0 – 5 | rear 6.0 x 11.0 – 5 |

125 MAX DD2 Masters

| | | | |
|-----|-------------------|----------------------|---------------------|
| Dry | Mojo D5 CIK Prime | front 4.5 x 10.0 – 5 | rear 7.1 x 11.0 – 5 |
| Wet | Mojo W5 CIK | front 4.5 x 10.0 – 5 | rear 6.0 x 11.0 – 5 |

2.3.2. Quantity for each category

1. Dry tires:

- 1 set is for non-qualifying practices (non parc fermé status)
- 1 set is for qualifying up to and including finals (non parc fermé status).

2. Wet tires:

- Maximum one set of MOJO W5 CIK will be handed out for non-qualifying practices (non parc fermé status)
- Organizer keeps the right to decide if a second set of MOJO W5 CIK will be handed out for qualifying practice up to and including final.
- Maximum 2 sets are available for the whole event for each category. They will only get handed out in case of rain (non parc fermé status).

3. Distribution and usage of tyres:

- The first set of slick tyres will be handed out after the chassis raffle. This set shall be used during the event for all non-qualifying practices.
- A certain number of used tyres from the first set (depending on the category) will be kept in parc fermé.
- After the last session of the non-qualifying practice each driver will receive a new set of slick tyres, which has to be used for the qualification phase up to and including the final. Each tyre of this set is marked with a barcode and the starting number.
- Each driver is responsible for checking that the marking of the starting number is visible outside, otherwise the tyre has to be presented in parc fermé for remarking.
- If there is a reasonable risk for rain, wet tyres (MOJO W5 CIK) together with rims will be handed out in time. Each tyre of these sets is marked with a barcode and the starting number.
- In case of mechanical failure of a tyre, each driver may exchange maximum 1 front and 1 rear tyre (each wet and dry), except if failure has been caused on purpose/misuse. In case of a mechanical failure of a tyre, the technical scrutineer will determine if the failure was due to material defect or has been caused on purpose/misuse. The technical scrutineer's decision will be final and not subject to protest or appeal.
- If the failure has not been caused on purpose/misuse the following rule will apply:
 - In all categories a new tire will be provided as replacement during Free Practice or before Qualifying. During Qualifying Heats, Pre-finals and Final a used tyre (with similar wear rate) will be provided as replacement.

2.3.3. All tyres are marked with barcode and can only be used by the assigned driver.

2.3.4. Tires are assigned (on a loan basis for the time of the event) to drivers, registered and routinely checked/scanned by means of the Rotax EMS (Event Management System).

2.3.5. Strictly no modifications or tire treatment is allowed. Tire check with “tire sniffer” Mini-RAE-Lite: Maximum value = 4ppm. Over this value there will be a second check. If the value remains over the 4ppm, Driver will be disqualified from the event.

2.3.6. Tyres must be mounted in accordance with the rotation markings defined on the tyre.

2.4. Engines

- Every engine is sealed with an engine seal with a unique serial number (barcode)
- Engines are randomly assigned (on a loan basis for the time of the event) to drivers, registered and routinely checked/scanned by means of the Rotax EMS (Event Management System).
- The mandatory settings, permitted adjustments and optional parts are defined in these RMCGF Technical Regulations 2022 and its Appendices.
- For all components outside the engine seal, the competitor is responsible to assure the conformity with the RMCGF Technical Regulations 2022 and its Appendices.
- At any moment of the event, a Driver / Entrant cutting or manipulating any seal or modifying any of the engine, and/or carburettor will be disqualified from the event.

2.5. Return of equipment

- At the end of the event Drivers must return the equipment according to the information’s about time, location and procedures of how to return the equipment defined by the organization.
- Equipment must be returned in the same working conditions as delivered. All equipment must be fully cleaned before returned, otherwise a 200€ fee it will be charged.
- Any damaged or missing part of the engine or accessories, toolbox and trolley must be paid for.
- Any damaged part of the chassis must be paid for.
- People appointed by the organizer (Rotax and chassis suppliers) will be responsible for completing an extensive control of the material handed out to the Driver.

2.6. Data acquisition

Systems which permit the reading/recording of following data only are allowed:

- Lap time
- Engine rpm (by induction on the high-tension cable)
- Engine coolant (water) temperature (sensor M10x1 mounted in the cylinder head)
- The speed of one wheel
- Acceleration in X/Y direction
- Position (via GPS system)
- Connection of the data acquisition system to the Rotax engine battery is allowed.

2.7. Safety equipment

According to Article 3, CIK-FIA technical regulations.

2.8. Fuel/Oil

Pre-mixed fuel will be provided via Parc Fermé for the whole event.

2.9. Advertising on engines

No sponsor stickers except ROTAX, BRP, MOJO, XPS are allowed on the engine and engine accessories.

3. MODIFICATIONS, LEGAL ADDITIONS, NON-TECH ITEMS, MEASUREMENTS

3.1. Modifications

- Neither the engine nor any of its ancillaries may be modified in any way. "Modified" is defined as any change in form, content or function that represents a condition of difference from that originally designed. This is to include the addition and/or omission of parts and/or material from the engine package assembly unless specifically allowed within these rules. The adjustment of elements specifically designed for that purpose shall not be classified as modifications, i.e. carburettor and exhaust valve adjustment screws.
- Genuine ROTAX components only that are specifically designed and supplied for the 125 Junior MAX, the 125 Senior MAX and the 125 MAX DD2 engine are legal, unless otherwise specified.
- Anything which is not expressly allowed in the RMCGF Technical Regulations 2022, is forbidden.

3.2. Legal additions

Temperature sensor for engine coolant (water).

3.3. Measurements

When taking any dimensional reading, of the following technical regulation, in the order of accuracy of 0,10 mm or even more precise, the temperature of the part must be between +10°C and +30°C.

4. TECHNICAL SPECIFICATION (OUTSIDE THE ENGINE AND CARBURETOR SEAL) FOR ROTAX KART ENGINES

125 Junior MAX, 125 Senior MAX and 125 MAX DD2

For all components outside the engine and carburettor seal, the competitor is responsible to assure the conformity with the RMCGF Technical Regulations 2022.

4.1. Balance drive

125 Junior MAX and 125 Senior MAX

Steel balance gears only (minimum width = 8,8 mm) are legal to be used.

Balance gears must be installed and must be aligned according to the illustration.

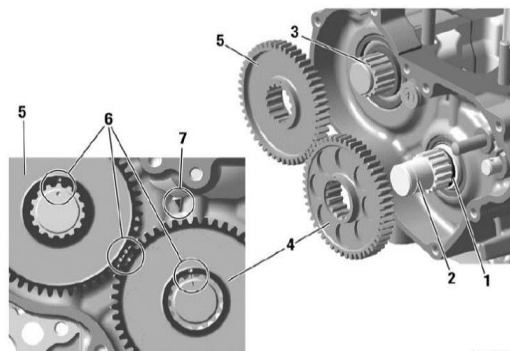

KA_125_0279

125 MAX DD2

Balance gear (1) must be fitted on primary shaft and must be aligned with the balance drive gear (2) according to the illustration.

The minimum weight of a dry balance gear (1) including bearing must not be lower than 255 grams.

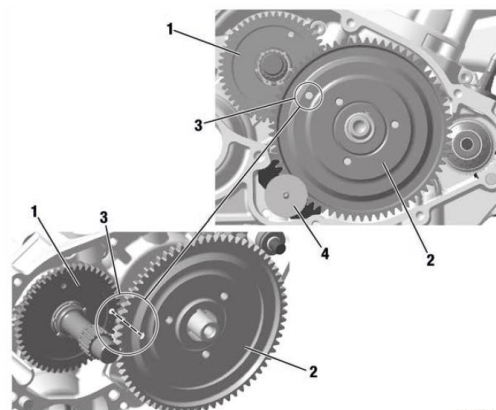

KA_125_0222

4.2. Centrifugal clutch

125 Junior MAX and 125 Senior MAX

Engagement speed of centrifugal clutch at maximum 4.000 rpm (the kart without driver must start to move).

The clutch (1) must show the wording "ROTAX".

O-ring (2) must be fitted.

The clutch drum (3) must show the wording "ROTAX".

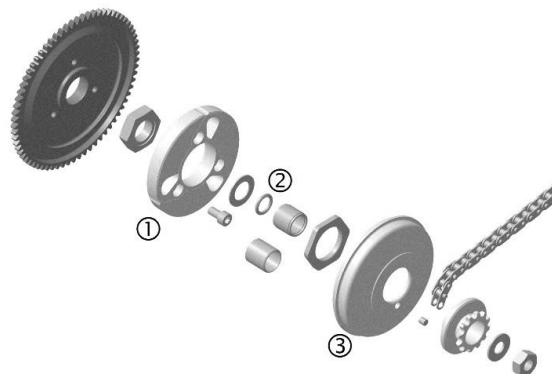

Signs of emission of grease or substance from the needle/plain bearing into the clutch drum may not exceed the like shown in the picture.

Contact area between clutch and clutch drum must be dry at any time – no lubrication allowed.



125 MAX DD2

Engagement speed of centrifugal clutch at maximum 4.000 rpm (the kart without driver must start to move).

The clutch (1) must show the wording "ROTAX".

O-ring (2) must be fitted.

The clutch drum (3) with drive gear must show the wording "ROTAX".

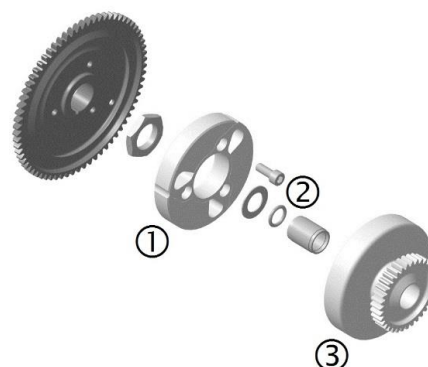

Clutch

Height of clutch (B)

125 Junior MAX and 125 Senior MAX: Minimum = 11,45 mm

125 MAX DD2: Minimum = 14,45 mm

Thickness of clutch shoe (A)

Minimum = 24,10 mm

Measurement must be done at the 3 open ends of the clutch, 5 - 10 mm from the machined groove (all clutch shoes must be completely closed at measurement - no gap).



Clutch drum (125 Junior MAX, 125 Senior MAX and 125 MAX DD2)

Outer diameter (C) of clutch drum

Minimum = 89,50 mm

Diameter must be measured with a sliding calliper just beside the radius from the shoulder (not at the open end of the clutch drum).

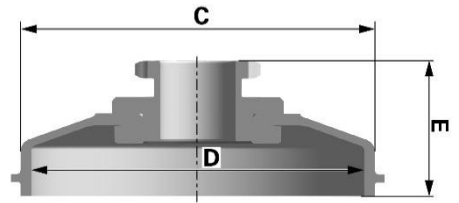

Inner diameter (D) of clutch drum

Maximum = 84,90 mm

Diameter must be measured with a sliding calliper. The measurement must be done in the middle of the clutch drum (in the contact area between clutch and clutch drum).

Height (E) of clutch drum with sprocket/primary gear:

125 Junior MAX and 125 Senior MAX – Minimum = 33,90 mm

125 MAX DD2 – Minimum = 39,50 mm

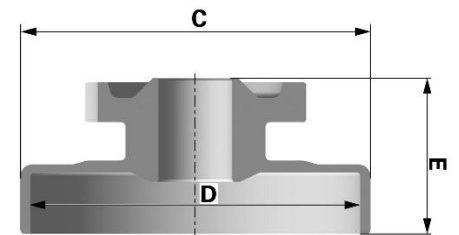

4.3. Primary drive (125 MAX DD2):

Original Rotax primary drive gears (4+5) must be used only.

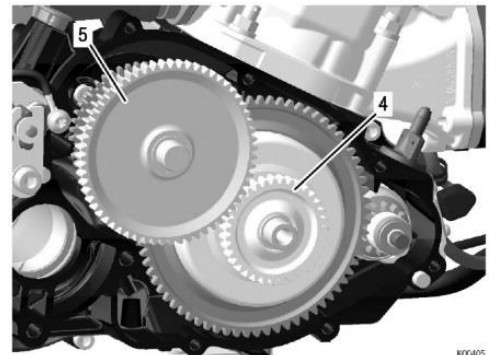

4.4. Gear shifting (125 MAX DD2)

The 2-speed gearbox must be operated from the steering wheel via the original Rotax paddle shift system (see illustration).

Cutting of the original aluminium shift paddles (30) or adding of non-original parts is not allowed.

Mounting the shift paddles (30) on the bottom or top side of the whip (23) is an allowed adjustment.

Optional parts (35-37) can be mounted on the shift paddle (30) in any position.

Bending the aluminium shift paddles to align them to the steering wheel is an allowed adjustment.

The whip (23) offers two connections for the cables (23) on each side for short travel or long travel. Both connections are legal to be used.

To change the connections of the cables to the whip (23) from left to right and right to left is an allowed adjustment.

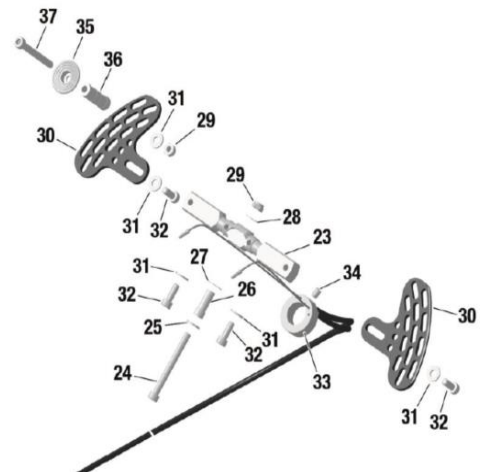

4.5. Exhaust valve (125 Senior MAX and 125 MAX DD2)

System must be used with all components fitted as shown in the illustration. The cylinder protection plate (45) is mandatory to be installed and must have a minimum thickness of 0,08mm. It is possible for the cylinder protection plate (45) to show signs of wear or damage. Bellow (10) must have green colour.

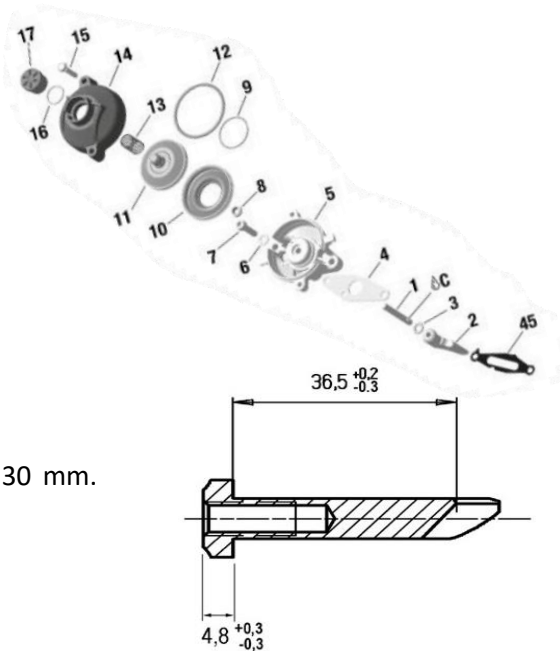

Exhaust valve

Length of the exhaust valve (item 2): 36,5 mm +0,20 mm/-0,30 mm.
Width of collar: 4,8 mm +/-0,3 mm

Distance of exhaust valve flange at cylinder to piston

Turn crankshaft until the piston just closes the exhaust port. Insert the exhaust valve gauge (Rotax 277030) as shown in the picture until it stops at the flange.

At the contact area between exhaust valve gauge (Rotax 277030) and the flange of the cylinder, a feeler gauge 0,05 mm may not fit between the gauge and the flange.



The measurement must be performed outside the exhaust valve contact area indicated in red below.

The use of the original impulse nozzle (1) in the pressure hose, connected to the magnet valve, is **not** allowed.

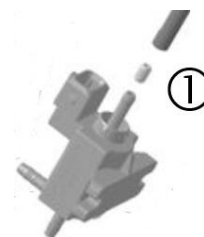

The electronic timed exhaust valve offers two different settings (A or B) for the opening of the exhaust valve.

(A)...additional ground cable not connected

(B)...additional ground cable connected

Both settings are legal to be used.



4.6. Ignition system

Dellorto digital battery ignition system, variable ignition timing, no adjustments possible.

Spark plug cap

Marked "ROTAX", red colour (see picture)



Ignition sensor

Sensor must show the in the first line the number marking 029600-0710.

A steel ball (diameter 3-5 mm) placed on circular surface of the sensor must stay in the centre of the circular surface.

Fitting an additional gasket between the sensor and the crankcase is not allowed.



Ignition coil (and magnet valve - 125 Senior MAX and 125 MAX DD2 only) must be fitted with all components according to the illustrations below.

In case the mounting bracket (125 Junior MAX and 125 Senior MAX only) conflicts with a chassis component, the additions of 2 spacers, one per mounting hole, with a maximum thickness of 20 mm between the mounting bracket and the gearbox cover is allowed.

125 Junior MAX and 125 Senior MAX



125 MAX DD2

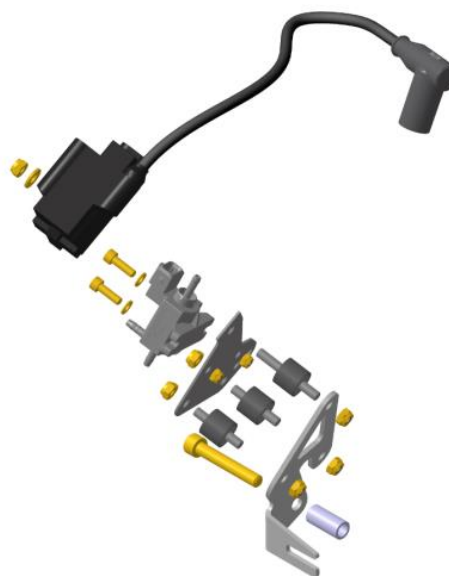

The visual appearance of the ignition coil must be identical with the pictures.

Ignition coil must show 2 pins at the terminal.

The ignition coil is labelled with two stickers, "BRP 666820" and "NIG 0105".

The ignition coil is still legal to be used also if one or both stickers disappeared.

Minimum length of the high-tension cable of the ignition coil is 210 mm (from outlet of ignition coil to outlet of spark plug connector = visible length of cable).



The electronic control unit (ECU) is labelled with stickers and is still legal also if the sticker is unreadable or disappeared.

125 Junior MAX: "666813"

125 Senior MAX: "666815"

125 MAX DD2: "666816"

The ECU must be checked with the ECU tester (Rotax part no. 276230) according to following procedure.

Disconnect engine cable harness from ECU.

Connect ECU tester cable harness to ECU.

Connect energy cable of ECU tester cable harness with the charging connector of engine cable harness.

At every connection with the battery the software version of the ECU tester will be indicated on the display for approx. 2 seconds.

The software version indicated on the display must be 2V00.

Start the test by pressing the button "✓" on the ECU tester.

After approx. 3 second the type of ECU ① that is actually tested will be indicated in the second line of the display.

After approx. 30 seconds the result ② of the test will be indicated in the first line of the display.



The ECU tester must indicate following results:

125 Junior MAX category

① 666813JNRMAX

② !! Test OK !!

125 Senior MAX category

① 666815MAX

② !! Test OK !!

125 MAX DD2 category

① 666816MAXDD2

② !! Test OK !!



4.7. Battery, battery fixation

Original battery with following specification must be used.
YUASA YT7B-BS (with "ROTAX" branding)

Battery must be fitted with the original battery clamp and battery cover (according to illustration below) on the left side of the seat.
Battery clamp (17) must be fixed to the chassis with two clamps (25-26) and 4 screws (25).

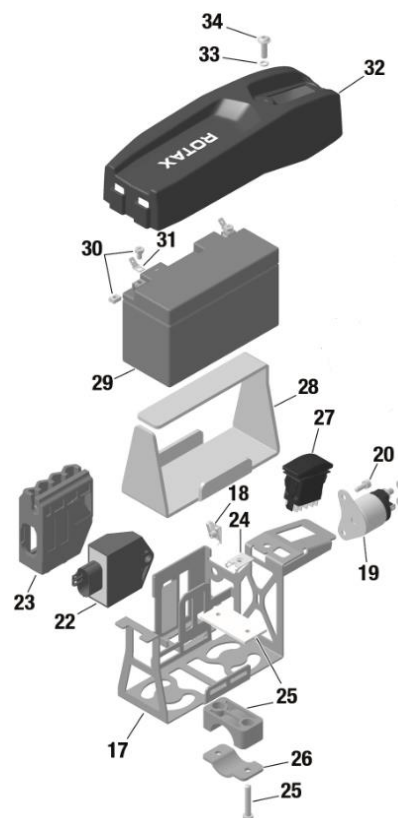

4.8. Intake silencer

a) 125 Junior MAX and 125 Senior MAX

- Intake silencer must be used with all parts as shown in the illustration and must be mounted on the support bracket with two screws (in dry and wet condition).
- Intake silencer tube (2) and carburettor socket (6) are marked with "ROTAX".
- Bottom intake silencer case (1) is marked on the inside with "225015".
- Top intake silencer case (5) is marked on the inside with "225025".
- Air filter has two layers and is marked with "Twin Air".
- Air filter (4) must be installed as shown in the illustration between the two holders (3) and must cover the complete area of the bottom intake silencer case (1).
- In wet (and dry) conditions it is not allowed to attach anything to the air box to protect the air inlet from water spray.

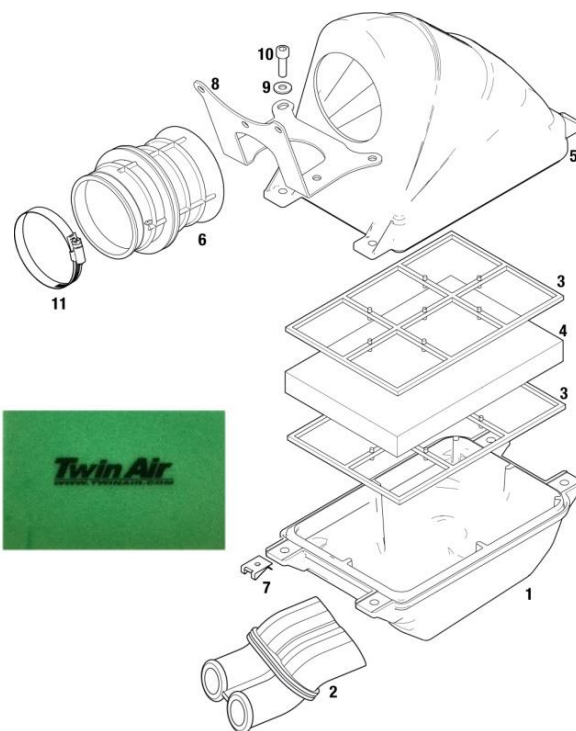

b) 125 MAX DD2

- Intake silencer must be used with all parts as shown in the illustration.
- Intake silencer case (1) is marked on the inside with "225013".
- Intake silencer cover (2) is marked on the inside with "225023".
- Air filter (3) with separate plastic frame (4) must be used. Intake silencer tube (5) and carburettor socket (7) are marked with "ROTAX".
- The air filter must be assembled between the intake silencer case and the intake silencer cover that the whole area of the intake silencer case is covered.
- In wet (and dry) condition it is not allowed to attach anything to the air box to protect the air inlet from water spray.

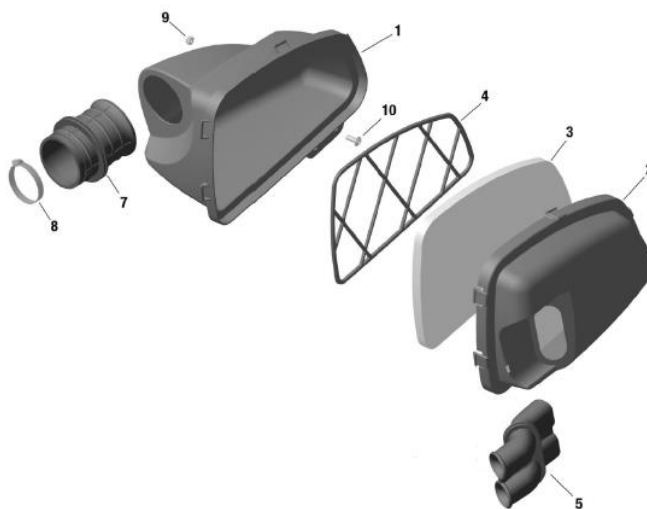

4.9. Carburettor

- Every carburettor is marked with a seal with a unique serial number (barcode).
- Carburettors are randomly assigned (on a loan basis for the time of the event) to drivers, registered and routinely checked/ scanned by means of the Rotax EMS (Event Management System).
- Carburettor slide must show the digits "45" in casting.
- Jet needle must be stamped with "K57". The position of the jet needle is free.
- Settings of the carburettor adjustment screws (idle and idle air) are free.
- All jets must be correctly seated and securely fitted at any time (tightened)!
- The complete inlet bore of the carburettor housing must show cast surface.
- The venturi hole of the carburettor insert can show signs of a CNC control machining.
- The two vent fittings must be connected to each other with the original air vent hose, minimum length = 155 mm.
- The ventilation hole of the vent hose must be placed at the rear side of the carburettor.
- The organiser / Technical scrutineer reserves the right to inspect and or exchange the carburettor or any of its components at any time during the event.

4.10. Fuel pump, fuel filter

MIKUNI diaphragm pump, (see picture) must be used and must be mounted as shown in the illustration.



a) 125 Junior MAX and 125 Senior MAX

Fuel pump must be mounted on the bottom side of the support bracket for the intake silencer.



b) 125 MAX DD2

Fuel pump must be mounted on the original support bracket attached to the clutch cover.

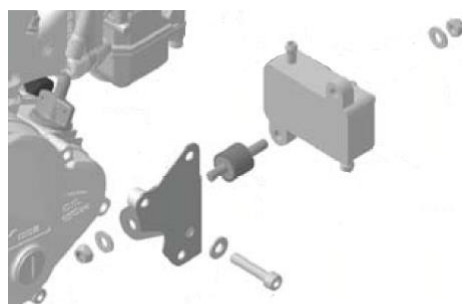

Fuel filter

Original fuel filter (see illustration) only is legal to be used. The fuel filter must be mounted between the fuel tank and prior to the fuel pump. Except the fuel line, the fuel pump and the original fuel filter no additional parts are legal to be mounted between fuel tank and carburettor.



4.11. Radiator

Radiator must be mounted with all components as shown in the respective illustration. To apply tape (neutral tape without advertising only) around the radiator is an allowed modification to control the air flow through the radiator. Tape may not be removed from the radiator during operation on the track. Any other non-original device to control the air flow through the radiator is prohibited.

a) 125 Junior MAX and 125 Senior MAX

The radiator must be mounted on the right side of the engine.

Cooling area: Height = 290 mm, width = 138 mm
 Thickness of radiator: 34 mm
 Radiator must be stamped on the side with "ROTAX".
 To remove the original flap is NOT allowed.

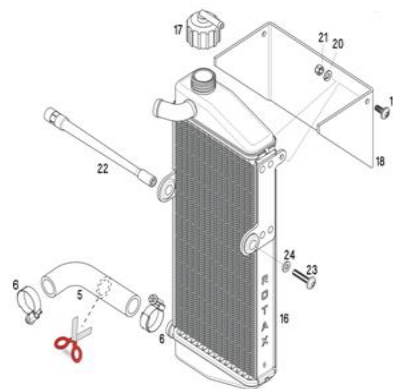

b) 125 MAX DD2

The radiator must be mounted on the left side beside the seat.
 The highest point of the radiator with cap may not be higher than 400 mm above the main tube of the kart chassis.

Cooling area: Height = 290 mm, width = 196 mm
 Thickness of radiator: 34 mm
 To remove the original flap is NOT allowed.

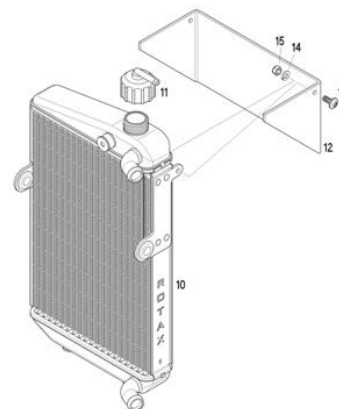

4.12. Engine coolant

Plain water without any additives must be used.

4.13. Exhaust system

4.13.1. Exhaust socket

125 Junior MAX, 125 Senior MAX and 125 MAX DD2

The measurement (C) must be at least 15,5 mm.
 To use up to 4 pieces of original Rotax exhaust springs, to fix the exhaust system to the exhaust socket, is allowed.
 To use a "safety wire" to fix the exhaust system to the exhaust socket is not allowed.

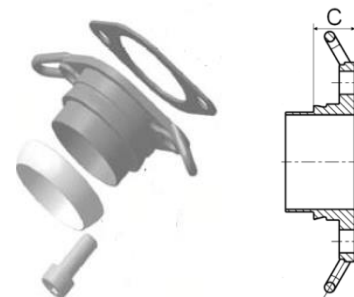

4.13.2. Exhaust pipe with silencer

Allowed modifications:

- Replacing the original rivets of the silencer end cap by 4 mm metric screws and corresponding locking nuts. The 3 x fixations (rivets, bolts and locking nuts) must be always secured tight to ensure a sealing between the perforated tube and exhaust system. The perforated tube must be fully inserted into the exhaust system (see top, right picture for reference) External protrusion of the outer sealing ring of the perforated tube is forbidden. (Indicated by the red arrow)
- Replacing the original isolating mat in the silencer by one new original isolating mat.



a) 125 Junior MAX and 125 Senior MAX

- A steel ball with 27,5 mm diameter must pass through the tuned pipe from the inlet and through the 180 degree elbow completely (silencer disconnected).
- The silencer must be mounted in a position where the direction of the 90° elbow outlet (direction of the hot exhaust gasses) does not harm any component of the chassis.
- Dimensions to be checked:
 Length of inlet cone: 590 mm +/-5 mm
 Length of cylindrical part of exhaust pipe: 130 mm +/-5 mm
 Length of end cone: 230 mm +/-5 mm

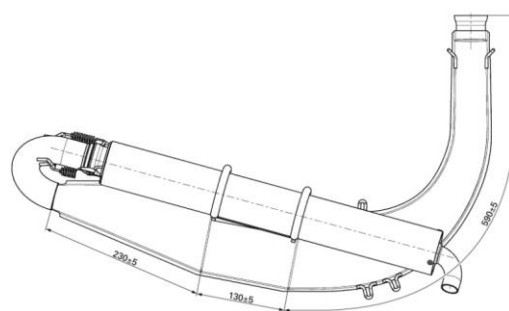

The only legal Isolation matting for 125 Junior and 125 Senior MAX is:
 ROTAX part number 297982

New size minimum 480 x 270mm (+/-10mm)
 New weight 207gr (176g – 238g)
 Used weight minimum 140g
 Used weight maximum 350g

b) 125 MAX DD2

- The silencer must be mounted in a position where the direction of the 90° elbow outlet (direction of the hot exhaust gasses) does not harm any component of the chassis.
- Dimensions to be checked:
 Length of inlet cone: 575 mm +/-5 mm
 Length of central part: 80 mm +/-5 mm
 Length of end cone: 240 mm +/-5 mm

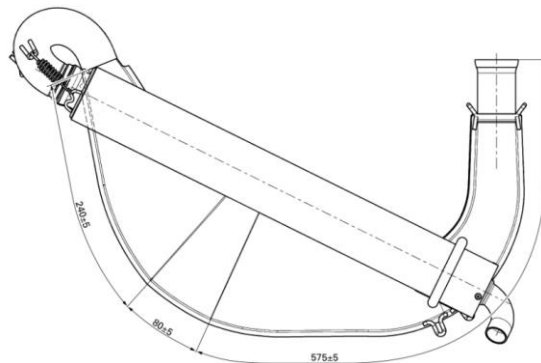

The only legal Isolation matting for 125 DD2 MAX is:
 ROTAX part number 297982

New size minimum 480 x 270mm (+/-10mm)
 New weight 207gr (176g – 238g)
 Used weight minimum 140g
 Used weight maximum 350g

4.14. Additional seat support (125 MAX DD2)

On the engine side, maximum one additional seat support can be used.

The additional seat support must be fastened to the engine using the Allen screw (2). The distance sleeve (3) may be removed for this purpose.

For the DD2 category, the seat support on the engine side, must be mounted as in the following picture. The uniball joint must always remain attached to the engine.

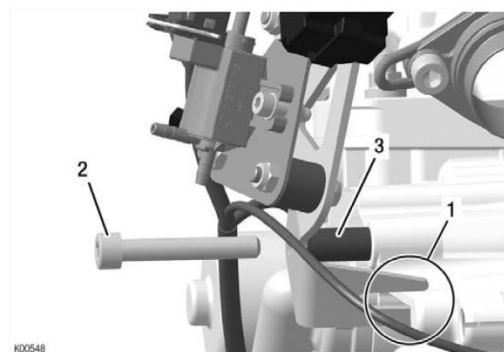

5. Permitted adjustments to the Chassis, Engine, Carburettor and drive train options

125 Junior MAX – Sodikart

| No. | Item | Specification |
|-----|---|---|
| 1 | Carburation and gearing mandatory for the 1 st free practice. | 130 Main Jet must be installed. Front sprocket 13, Rear sprocket 72 teeth. |
| 2 | Carburation and gearing options for the 2 nd free practice through to the Finals | Any main jet from the kit supplied can be used. (125, 126, 127, 128, 129, 130, 131, 132, 133 & 134) Front sprocket 13 or (12 tooth, just in combination with wet tyres) Rear sprocket 72, 73, 74 or 75 teeth. |
| 3 | Spark plug type and gap | NGK GR8DI. Filler gauge 1,00 mm must not fit in between the two electrodes. |
| 4 | Chain length and type | Only chains as supplied at the event by the manufacturer are legal to be used. 100 or 102 chain length. |
| 5 | Ride height | Front: free Rear: free |
| 6 | Camber and Castor | Changes are allowed |
| 7 | Ackerman settings | Only the hole inside can be used on the front stub axle |
| 8 | Seat supports | Maximum 1 extra on each side |
| 9 | Seat fixing | Seat screws (2) from the bottom can be loosed |
| 10 | Wheel base | As supplied |
| 11 | 3 rd Bearing | Must be always tight |
| 12 | Other notes | All side bars and front bars (crash protection) are required to be secured. Side bars can be loosed |
| 13 | Optional parts | 2 types of pedal kit. Angled steering wheel boss. One additional plastic shim with an angle of 8 degrees is allowed. |

From the 2nd non-qualifying practice ROTAX recommends: Jet 126, needle position 4, 0,65 mm spark plug gap and 55°C engine temperature

Note: Only standard components as supplied at the event by the manufacturer for the specific category may be used in accordance with the RMC GF Technical Regulations 2022 and its appendices.

125 Senior MAX – Sodikart

| No. | Item | Specification |
|-----|---|---|
| 1 | Carburation and gearing mandatory for the 1 st free practice. | 130 Main Jet must be installed. Front sprocket 13, Rear sprocket 73 teeth. |
| 2 | Carburation and gearing options for the 2 nd free practice through to the Finals | Any main jet from the kit supplied can be used. (125, 126, 127, 128, 129, 130, 131, 132, 133 & 134) Front sprocket 13 or (12 tooth, just in combination with wet tyres) Rear sprocket 73, 74, 75 or 76 teeth. |
| 3 | Spark plug type and gap | NGK GR8DI. Filler gauge 1,00 mm must not fit in between the two electrodes. |
| 4 | Chain length and type | Only chains as supplied at the event by the manufacturer are legal to be used. 100 & 102 chain length. |
| 5 | Ride height | Front: free Rear: free |
| 6 | Camber and Castor | Changes are allowed |
| 7 | Ackerman settings | Only the hole inside can be used on the front stub axle |
| 8 | Seat supports | Maximum 1 extra on each side |
| 9 | Seat fixing | Seat screws (2) from the bottom can be loosed |
| 10 | Wheel base | As supplied |
| 11 | 3 rd Bearing | Must be always tight |
| 12 | Other notes | All side bars and front bars (crash protection) are required to be secured tight at all times. Side bars can be loosed |
| 13 | Optional parts | One additional plastic shim with an angle of 8 degrees is allowed |

From the 2nd non-qualifying practice ROTAX recommends: Jet 128, needle position 4, 0,65mm spark plug gap and 55°C engine temperature

Note: Only standard components as supplied at the event by the manufacturer for the specific category may be used in accordance with the RMC GF Technical Regulations 2022 and its appendices.

125 MAX DD2 – BirelART

| No. | Item | Specification |
|-----|---|--|
| 1 | Carburation and gearing mandatory for the 1 st free practice. | 134 Main Jet must be installed. Gear ratio set 36 / 61 Please note: you will need to install the correct main jet |
| 2 | Carburation and gearing options for the 2 nd free practice through to the Finals | Any main jet from the kit supplied can be used. (128, 129, 130, 131, 132, 133, 134, 135, 136, 137 & 138) Gear ratio sets (36 / 61), (37 / 60) or (35 / 62 in combination with wet tyres only) |
| 3 | Spark plug type and gap | NGK GR8DI. Filler gauge 1,00 mm must not fit in between the two electrodes. |
| 4 | Ride height | Front: Only to go up with the chassis |
| 5 | Camber and Castor | Kart is standard assembled with graduated bushing 0,5 and graduated bushing 0. Allowed the additional kit of 2 bushings 1,5 degrees |
| 6 | Ackerman settings | Allowed the adjustment in all 3 positions |
| 7 | Seat supports | It is possible to add a seat support on the left. Maximum 2 on the left and 1 on the right |
| 8 | Seat fixing | Seat screws (2) from the bottom can be loosed |
| 9 | Rear bumper | The 2 supports for the rear bumper must be mounted tight to the frame at all times. Screws of the rear bumper may be loose to enable a lateral movement of the rear bumper only. |
| 10 | Wheel base | 1045 mm |
| 11 | 3 rd Bearing | N/A |
| 12 | Other notes | All side bars and front bars (crash protection) are required to be secured tight at all times. Removal of front bar stabilizer is allowed |
| 13 | Optional parts | Angled steering wheel boss |
| 14 | Steering | One additional plastic shim with an angle of 10 degrees is allowed |

From the 2nd non-qualifying practice ROTAX recommends: Jet 132, needle position 4, 0,65mm spark plug gap and 55°C engine temperature

Note: Only standard components as supplied at the event by the manufacturer for the specific category may be used in accordance with the RMC GF Technical Regulations 2022 and its appendices.

125 MAX DD2 Masters – IPKarting Praga

| No. | Item | Specification |
|-----|---|--|
| 1 | Carburation and gearing mandatory for the 1 st free practice. | 134 Main Jet must be installed. Gear ratio set 36 / 61 Please note: you will need to install the correct main jet |
| 2 | Carburation and gearing options for the 2 nd free practice through to the Finals | Any main jet from the kit supplied can be used. (128, 129, 130, 131, 132, 133, 134, 135, 136, 137 & 138) Gear ratio sets (36 / 61), (37 / 60) or (35 / 62 in combination with wet tyres only) |
| 3 | Spark plug type and gap | NGK GR8DI. Filler gauge 1,00 mm must not fit in between the two electrodes. |
| 4 | Ride height | Front: free adjustments Rear: free adjustments |
| 5 | Camber and Castor | Only the supplied kit maybe used, settings are free to adjustment 0 / 0,5 / 1 / 2 degrees eccentrics can be used only |
| 6 | Ackerman settings | Only the supplied parts maybe used, settings are free to adjustment |
| 7 | Seat supports | 1x Left and 1x Right must be used |
| 8 | Seat fixing | Must be tight at all times. |
| 9 | Rear bumper | The 2 supports for the rear bumper must be mounted tight to the frame at all times. Screws of the rear bumper may be loose to enable only up and down movement of the rear bumper only. |
| 10 | Wheel base | 1045mm |
| 11 | 3 rd Bearing | N/A |
| 12 | Other notes | All side bars and front bars (crash protection) are required to be secured tight at all times |
| 13 | Optional parts | Angled steering wheel boss, Shorter brake rod, Steering rod L270mm, adjustable foot rest system and seat side protection kit. All bolts and nuts need to be tight at anytime |
| 14 | Seat | IPK Racing silver (sizes XS, 1, 1+, 2 & 3) |
| 15 | Side bodywork supports | Must be fixed at anytime |
| 16 | Engine mounting | Engine need to be fixed with 3 engine mounts |

From the 2nd non-qualifying practice ROTAX recommends: Jet 132, needle position 4, 0,65mm spark plug gap and 55°C engine temperature

Note: Only standard components as supplied at the event by the manufacturer for the specific category may be used in accordance with the RMC GF Technical Regulations 2022 and its appendices.