

8º RALI SANTA JOANA

PONTOURBANO

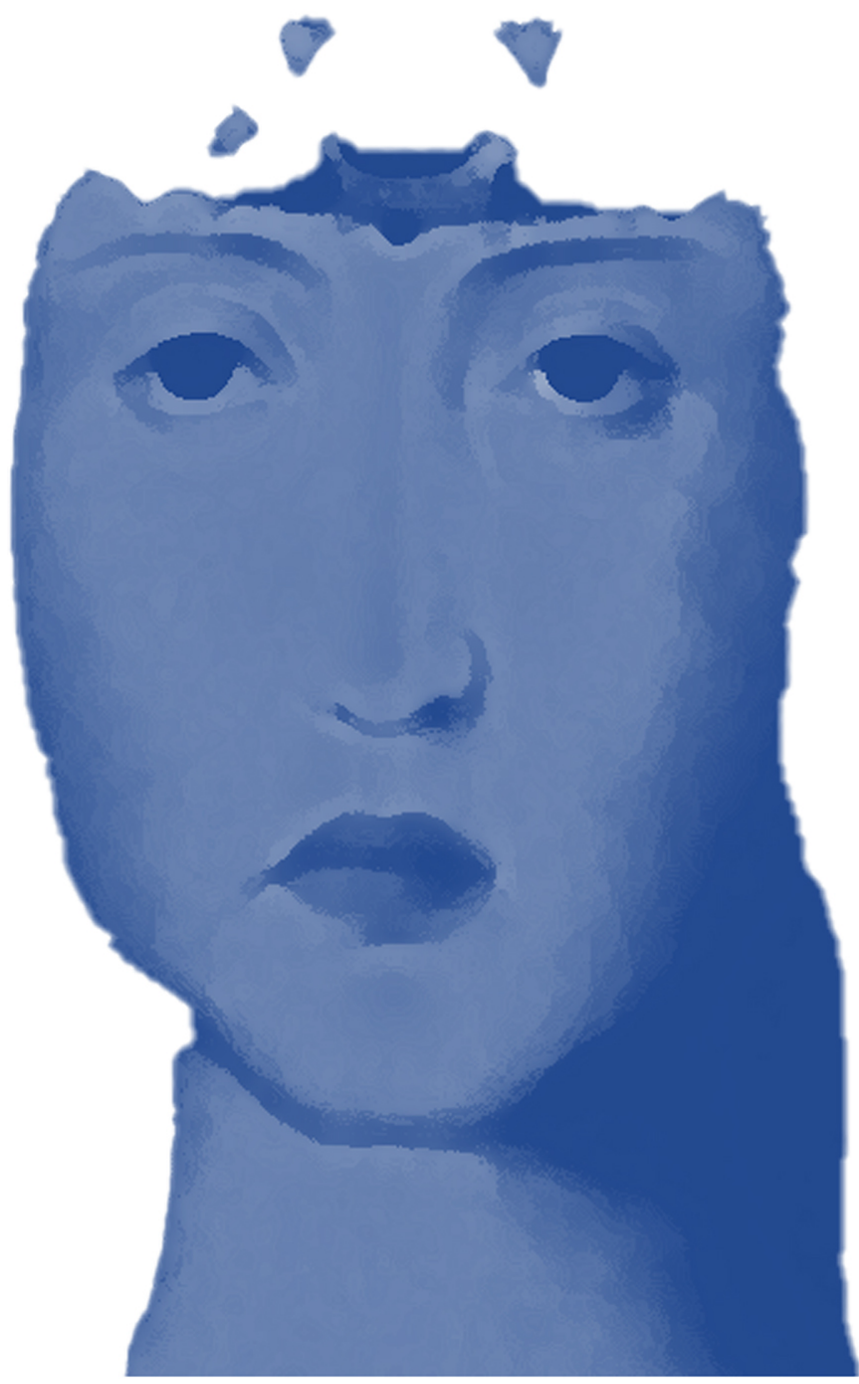

VEIRO, 26/27 MAIO 2023

TROÇO
AFERIÇÃO

**8º Rali Santa Joana
PONTO URBANO**



ACESSO AO TROÇO DE AFERIÇÃO

AVEIRO

N 40,6392

W 8,6534

1



Secretariado
N 40° 38' 20,95 ''
W 8° 39' 12,11 ''

**INICIO DO TROÇO DO AFERIÇÃO
SENTIDO AVEIRO/GAFANHA**

0 125 m

2

**8º Rali Santa Joana
PONTO URBANO**



TROÇO AFERIÇÃO

ESTRADA DA RIA - GAFANHA DA NAZARÉ

IDA E INVERSÃO

N 40,6417

W 8,6631



Início

N 40° 38' 30,45 "

W 8° 39' 47,30 "

Final







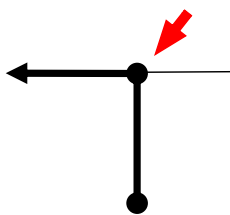
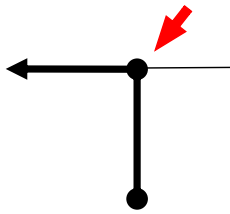
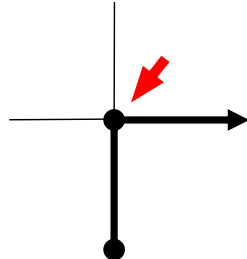
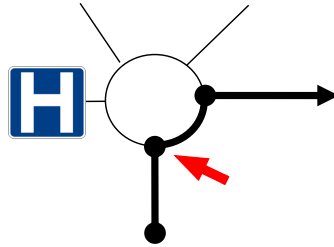
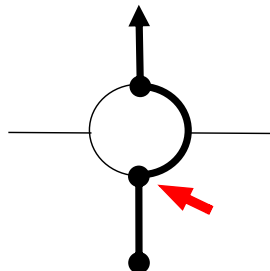



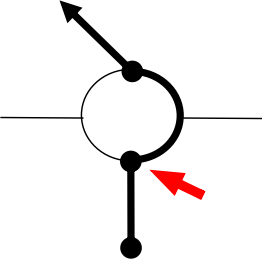

N 40° 37' 54,80 "

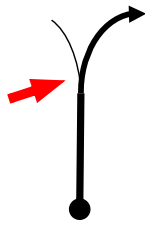
W 8° 41' 16,70 "



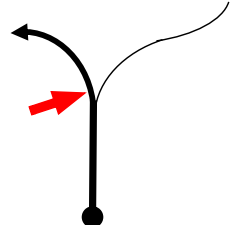

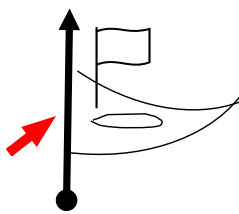
Troço	ACESSO DO SECRETARIADO AO TROÇO AFERIÇÃO			8º Rali Santa Joana PONTO URBANO	
Secção					
Distância		KM			
Horas		Min			

Total	Parcial	ID	Direcção	Informação	Dist. Regressiva
0,00	0,00	1			2,11
0,08	0,08	2			2,03
0,29	0,21	3			1,82
0,54	0,25	4		<div style="border: 1px solid black; padding: 2px; display: inline-block; margin-bottom: 5px;">FERRYBOAT →</div> <div style="border: 1px solid black; padding: 2px; display: inline-block; margin-top: 5px;">PORTO/ VISEU →</div>	1,57
0,91	0,37	5		<div style="border: 1px solid black; padding: 2px; display: inline-block; margin-bottom: 5px;">HOTEL AVEIROCENTER →</div>	1,20



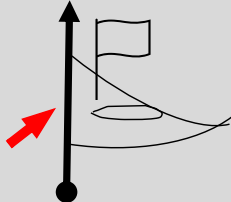



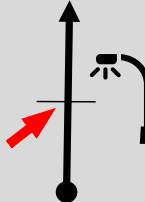

Troço	ACESSO DO SECRETARIADO AO TROÇÇO AFERIÇÃO			8º Rali Santa Joana PONTO URBANO	
Secção					
Distância		KM			
Horas		Min			

Total	Parcial	ID	Direcção	Informação	Dist. Regressiva
1,38	0,47	6		<p>CENTRO  </p> <p> PRAIAS</p> <p> ZONA PORTUÁRIA</p>	0,73
1,67	0,29	7		<p> SPORTING CLUBE AVEIRO</p> <p> ALFANDEGA</p> <p> PRAIAS</p> <p> A25</p>	0,44
1,75	0,08	8		<p> POSTO NÁUTICO CLUBE GALITOS</p> <p> CMIA</p>	0,35
2,11	0,35	9		<p></p> <p>FERRO DE SINAL</p>	0,00

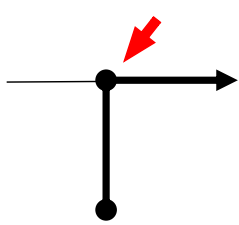
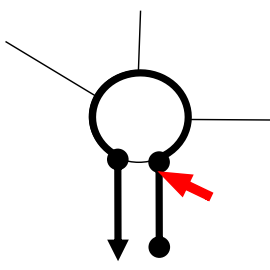
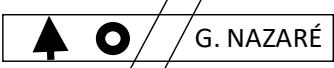

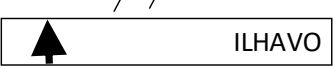
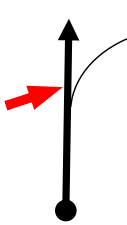
Troço	TROÇO DE AFERIÇÃO			8º Rali Santa Joana PONTO URBANO	
Secção					
Distância		KM			
Horas		Min			

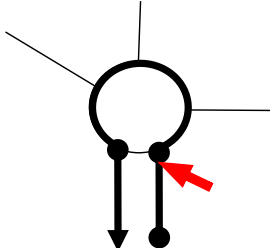
Total	Parcial	ID	Direcção	Informação	Dist. Regressiva
0,000	0,00	1		INICIO TROÇO AFERIÇÃO	3,27
0,715	0,72	2			2,56
1,064	0,35	3			2,21
1,762	0,70	4			1,51
2,137	0,38	5			1,13



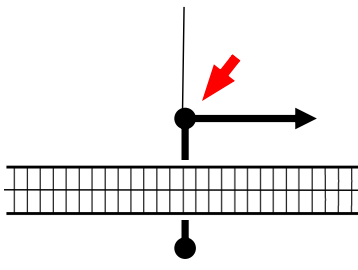
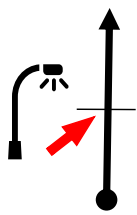

Troço	TROÇO DE AFERIÇÃO			8º Rali Santa Joana PONTO URBANO	
Secção					
Distância		KM			
Horas		Min			

Total	Parcial	ID	Direcção	Informação	Dist. Regressiva
2,508	0,37	6		 CANDEEIRO FIM TROÇO DE AFERIÇÃO	0,76
2,60	0,09	7			0,67
2,65	0,05	8		  	0,62
2,84	0,19	9			0,43
2,95	0,11	10		 	0,32

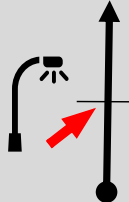

Troço	TROÇO DE AFERIÇÃO			8º Rali Santa Joana PONTO URBANO	
Secção					
Distância		KM			
Horas		Min			

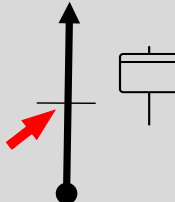
Total	Parcial	ID	Direcção	Informação	Dist. Regressiva
3,15	0,20	11			0,12
3,27	0,12	12		 CANDEEIRO INICIO TROÇO DE AFERIÇÃO INVERSO	0,00

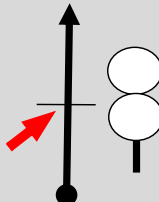
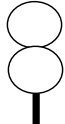
Troço	TROÇO DE AFERIÇÃO INVERSO		8º Rali Santa Joana PONTO URBANO	
Secção				
Distância		KM		
Horas		Min		

Total	Parcial	ID	Direcção	Informação	Dist. Regressiva
0,00	0,00	1		INICIO TROÇO AFERIÇÃO INVERSO	3,89
0,529	0,53	2			3,36
1,321	0,79	3		 PERNA DE SUPORTE DE PLACAS NA A25	2,57
1,412	0,09	4			2,48
2,099	0,69	5		 COSTAS NA A25	1,79

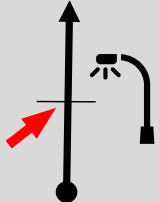
Troço	TROÇO DE AFERIÇÃO INVERSO			8º Rali Santa Joana PONTO URBANO	
Secção					
Distância		KM			
Horas		Min			

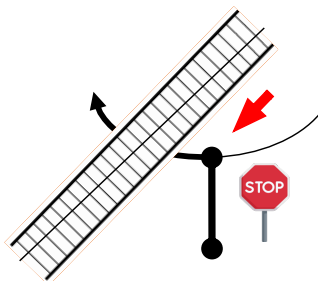
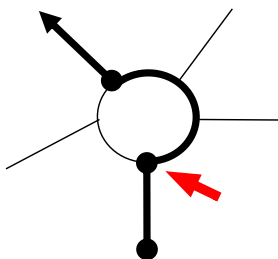
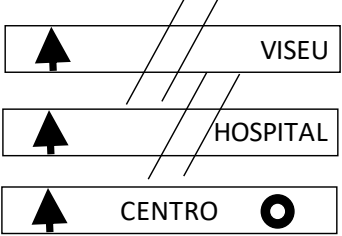
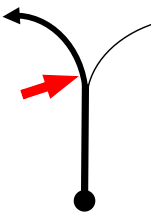
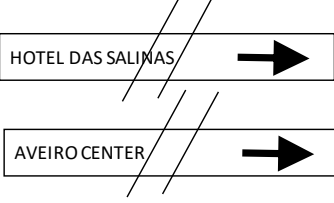
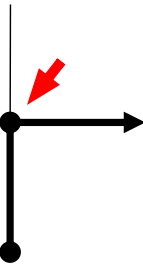
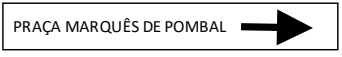
Total	Parcial	ID	Direcção	Informação	Dist. Regressiva
2,640	0,54	6		 CANDEIEIRO FRENTE CASOTA DE BETÃO COM PORTA VERDE Nº20 FIM TROÇO DE AFERIÇÃO INVERSO	1,25
2,88	0,24	7			1,01
3,11	0,23	8			0,78
3,44	0,33	9			0,45
3,60	0,16	10			0,29

Troço	TROÇO DE AFERIÇÃO INVERSO			8º Rali Santa Joana PONTO URBANO	
Secção					
Distância		KM			
Horas		Min			

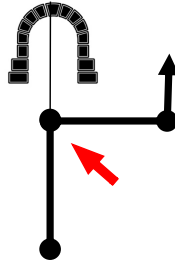
Total	Parcial	ID	Direcção	Informação	Dist. Regressiva
3,89	0,29	11			0,00

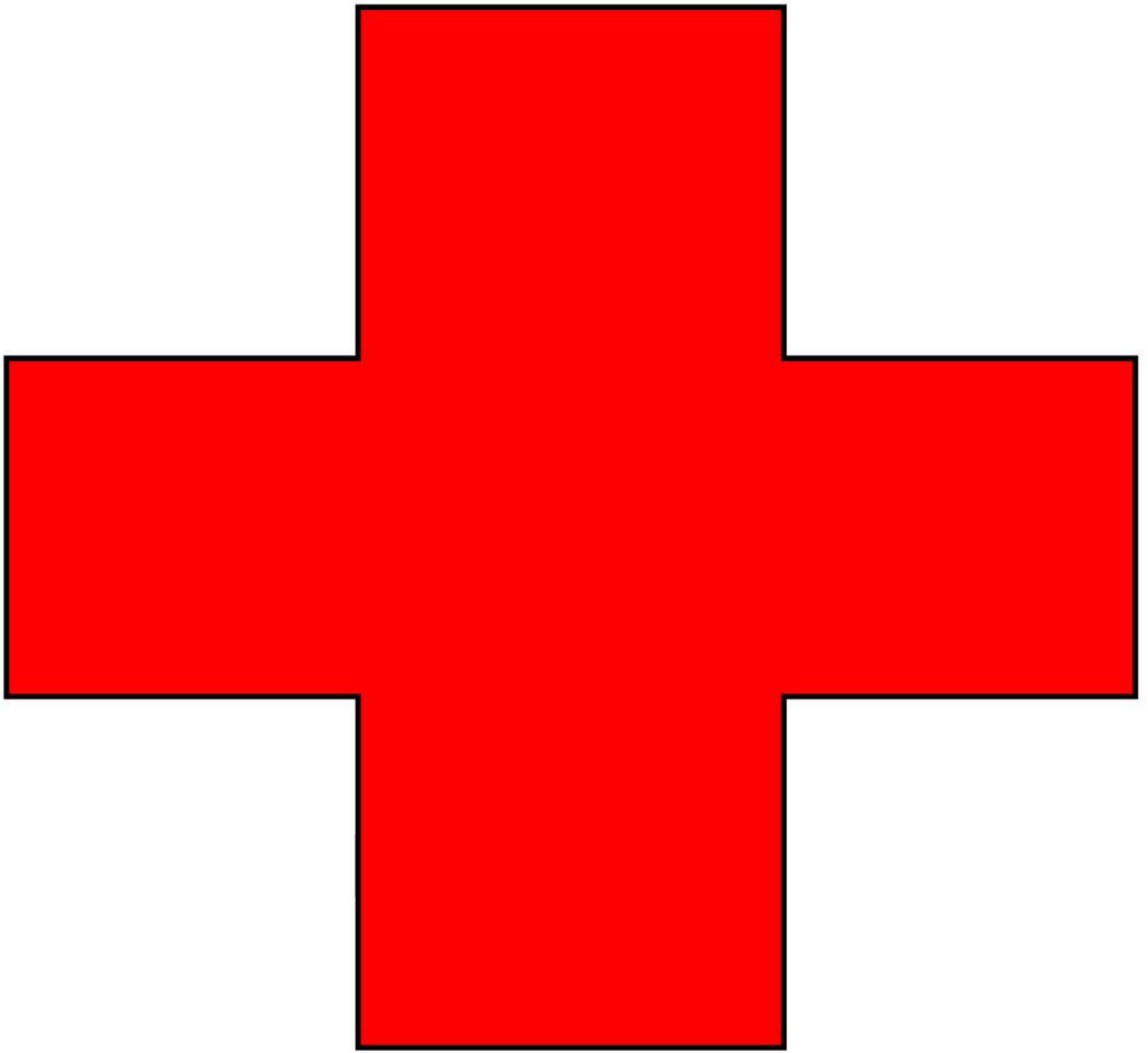

**Mostre este sinal aos condutores que o seguem
se tiver necessidade de uma ambulância**

**Show this sign to next drivers
if you require ambulance**

OK